

CONTENTS

General Features	3
I/O Configuration	3
System Configuration	Higher Level Communication	4
	Links between PLCs	4
	PLC Lower Level Communications	5
Standard Specifications	Common Specifications • Power Supply Specifications	6
	Functional Specifications	7
	Sequence CPU Module Functional Specifications for FA-M3 “Value”/FA-M3 Value II	10, 11
	Ladder Sequence Basic Instructions/ Application Instructions	12
REAL-TIME BASIC	23
Module Specifications	I/O Modules.....	25
	Special Modules.....	28
	YHLS Slave Units	32
	Restrictions on Module Installation Position.....	34
	Restrictions on the Number of I/O Modules	35
	Standard Accessories • Spare Parts	37
Current Consumption	Power Supply Modules • Basic Modules	38
	FA-M3 Value and Value II.....	38
	I/O Modules.....	39
	Special Modules.....	40
	Severity of Failures and LED Display.....	41
External Dimensions • FA-M3 Approved / Compliant Standard	43

Blank Page

General

The Range-free Multi-controller FA-M3 is a next-generation programmable controller, which achieves high performance through its ultra high-speed processing and stable control features. It incorporates a space-saving compact design, supports versatile ranges with cover for up to 8192 input/output points, and is equipped with a variety of advanced modules, which can be used to configure a wide range of applications.

With the FA-M3, decreased total cost of ownership (TCO) can be realized through openness, improved functions and reduction in the size of machines and facilities.

Features

The increased speed of the FA-M3 has been achieved as a result of adopting the concept High Speed IPRS which is based on four factors: Instruction, Process, Response and Scan. This contributed to increased accuracy of instruments and productivity. The FA-M3 has also inherited structured programming and uses an "object ladder"™ to create an efficient total design, all the way from planning to maintenance.

*: "Object ladder" is a program development concept aimed at dramatically improving customization efficiency by integrating programs and devices into independent objects (e.g., blocks) on function basis.

● Ultra-high Speed Processing

The high-speed instruction processing capability of the FA-M3 makes it ideal for applications that require high speed and quick response.

- The F3SP28 and F3SP38 CPUs achieve a scan time of 1 ms for a 6K steps program*.
- The F3SP53, F3SP58, F3SP59, F3SP66 and F3SP67 CPUs achieve a scan time of 1 ms for a 20K steps program*.
- The F3SP71 and F3SP76 CPUs achieve a scan time of 1 ms for a 100K steps program*.

*: The scan times mentioned above can only be achieved under specific conditions and vary depending on the contents of the program and system configuration.

● Sensor Control Function

This function allows one CPU to perform a parallel operation at a minimum scan time of 200 μs (100 μs for F3SP7□) while carrying out a main scan during program operation. It enables one block of the program to be executed at high-speed and fixed intervals independently of a main scan, which features high performance and advanced functionalities.

● Built-in Network Function (when using F3SP6□, F3SP7□)

These sequence CPU modules have a built-in network function, which complements high-speed control with fast access and storage of large files. With pre-installed support for a wide range of common communication protocols, it enables transfer of large files.

● Built-in Modbus/TCP Slave (Server) Function (when using F3SP7□)

These sequence CPU modules have a built-in Modbus/TCP slave (server) function, which enables communication with a Modbus master (client) device via the module's communication port without need of programming on the module end.

● Multiple CPUs

The FA-M3 can accommodate up to 4 CPUs in one base module depending on the system size, program size and CPU aptitude. The supported CPU modules include sequence CPU modules, as well as BASIC CPU modules.

● Program Reusability

Object ladder allows integration of programs with devices into components on function basis. This improves the reusability of user software and efficiency of machine custom design.

- Local Device

Devices used as variables in different user blocks or component macros are completely independent, and can be allocated to different devices even if they share the same name so that global analyses and modification of the device structure for reuse of ladders are not necessary.

● Efficient System Maintenance

- Oscilloscope-like Sampling Trace Function

The CPU module is capable of acquiring high-speed data, which cannot be acquired using a PC. Various analysis functions, such as inter-point analysis and range adjustment are supported, enabling efficient troubleshooting when equipment fails.

● Open Network

The FA-M3 supports open network protocols such as Ethernet, FL-net, DeviceNet, AS-interface, PROFIBUS-DP, GP-IB, RS-232-C/422 and Automated Distribution Protocol, and provides a range of modules for use on a variety of networks ranging from field networks to system configuration networks.



I/O Configuration

● Up to Seven Additional Subunits for I/O Extension

Up to 8192 inputs and outputs can be processed (for F3SP35, F3SP38, F3SP58, F3SP59, F3SP67 and F3SP76).

● Main Unit and Subunit

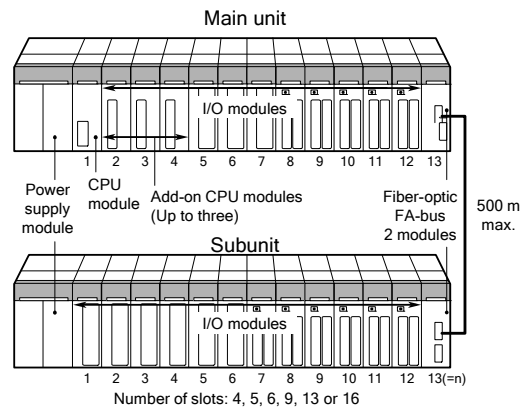

● Subunit Extension

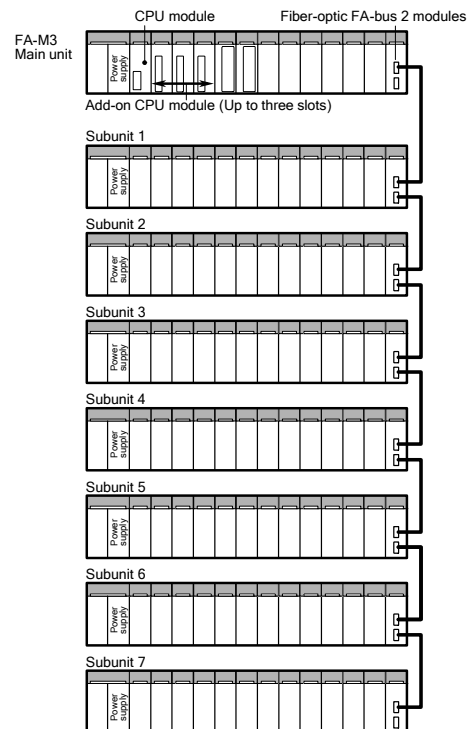

System Configuration

Higher Level Communication

- (1) Connecting to a Workstation or PC via Ethernet

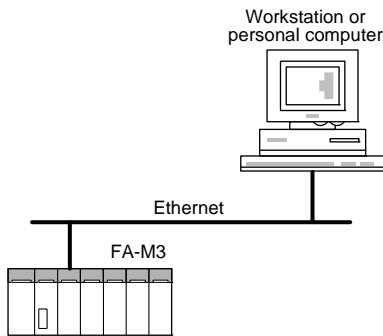

- (2) Connecting to a Personal Computer via Public Telephone Network

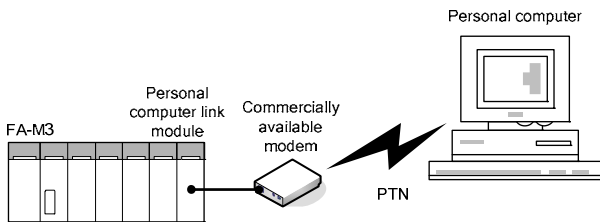

- (3) Connecting to a Touch Operation Panel via Personal Computer Link

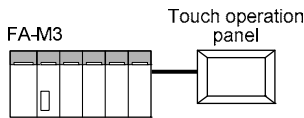

- (4) Connecting to a Touch Operation Panel via Ethernet

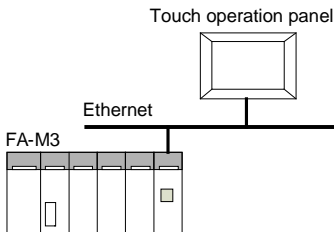

Links between PLCs

- (1) Connecting between FA-M3s via FL-net (OPCN-2) modules

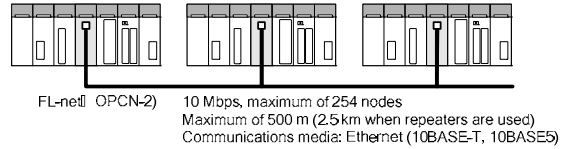

FL-net (OPCN-2) is an open, multi-vendor network, which not only allows high-speed data transfer between FA-M3 units but also connection to third-party FA controllers.

- (2) Connecting between FA-M3s via FA link H modules

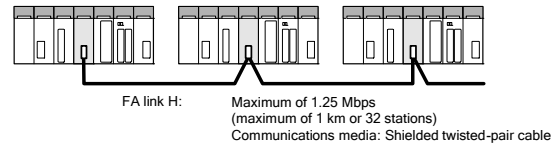

Use the FA link H modules for exchanging data between FA-M3s.

- (3) Connecting between FA-M3s via Fiber-optic FA link H modules

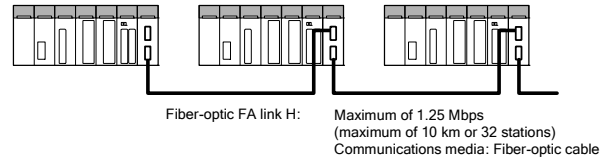

The fiber-optic FA link H modules permit high-speed data exchange between FA-M3s.

■ PLC Lower Level Communications

(1) Adding FA-M3s via a Fiber-optic FA-bus Type 2 (remote I/O)

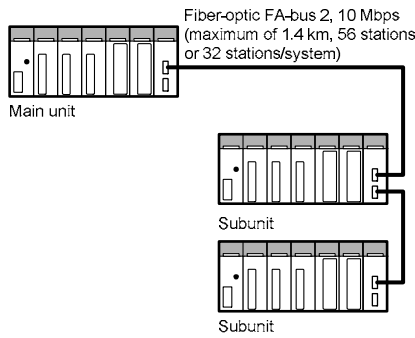

Use a fiber-optic FA-bus Type 2 module when augmenting I/O devices in a multi-station or long distance configuration.

(2) Adding FA-M3s via a FA-bus Type 2 (remote I/O)

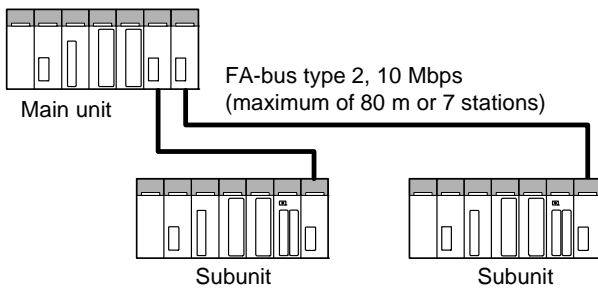

Use a FA-bus Type 2 module when adding subunits.

(3) Connecting to YHLS Slave Units via YHLS

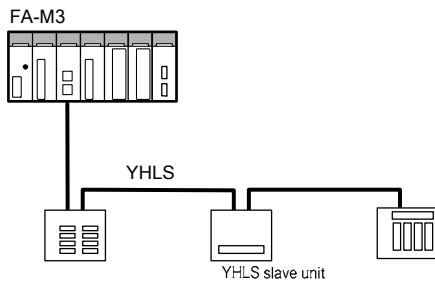

YHLS (Yokogawa Hi-speed Link System) enables easy implementation of high-speed 1:N remote I/O communication systems.

(4) Connecting to a Temperature Controller via a UT Link

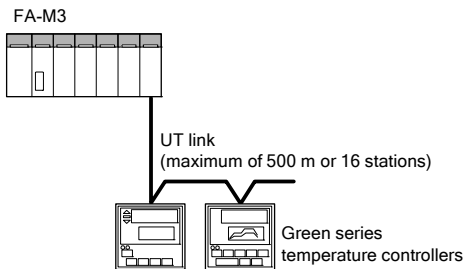

(5) Connecting to Measuring Instruments via a GP-IB

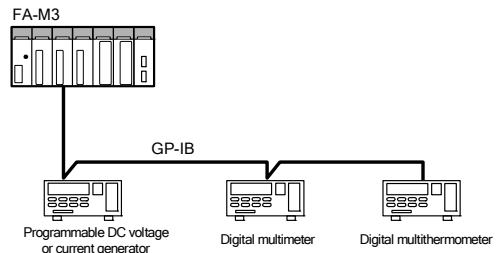

(6) Connecting to a Barcode Reader via RS-422 Ladder Communications

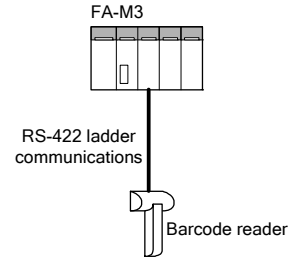

(7) Connecting to Remote I/O and Sensors via DeviceNet

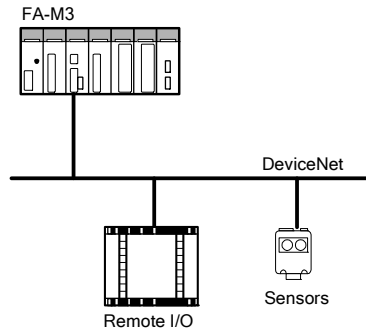

(8) Connecting to Ethernet-enabled Equipment (via a sequence CPU with network function)

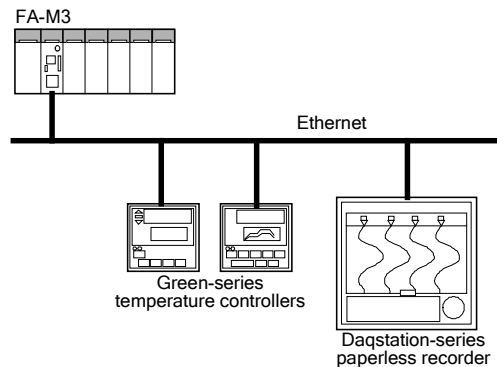

Standard Specifications

Common Specifications

Item		Specifications	
Environment	Operating ambient temperature range ¹	0°C to 55°C	
	Operating ambient humidity range	10 to 90% RH (non-condensing)	
	Operating environment	Must be free of corrosive gases, flammable gases or heavy dust.	
	Storage ambient temperature range	-20°C to 75°C	
	Storage ambient humidity range	10 to 90% RH (non-condensing)	
	Grounding	JIS Class D grounding	
	Noise immunity	Tested using a noise simulator with a noise voltage of 1500 V _{p-p} , pulse width of 1 μs, rise time of 1 ns, and repetition frequency of 25 to 60 Hz. For CE Marking-compliant modules, compliant to EN61326-1, EN61326-2-3 ⁶ and EN61000-6-2	
	Vibration resistance	Tested in compliance with JIS C0040 under the following conditions: - Frequency ranges: 10 to 57 Hz with an amplitude of 0.075 mm 57 to 150 Hz with an acceleration of 9.8 m/s ² (1 G) - Direction and sweep cycles: 10 times each in the X, Y, and Z directions	
Structure & Appearance	Shock resistance	Tested in compliance with JIS C0041 under the following conditions: - Direction and sweep cycles: 3 times each in the X, Y, and Z directions with an acceleration of 147 m/s ² (98 m/s ² with DIN-rail mounting)	
	Structure	Designed for mounting inside a panel enclosure	
	Altitude of installation	Max. of 2000 m above sea level	
	Compliance with safety and EMC standards ²	UL	UL508 approved, File No.E188707 (Overvoltage Category ³ II, Pollution Degree ⁴ 2)
			CE
		Low Voltage Directive	
		C-Tick	EMC Framework EN 61326-1 Class A, Table 2 (for use in industrial locations) EN 55011 Class A, Group 1 compliance
	Cooling method	Natural-air cooled	
Mounting	Direct mounting with M4-size setscrews ⁵ or DIN-rail mounting (except for F3BU16-0N module)		
Finish color	Light cobalt blue, equivalent to Munsell 6.2PB 4.6/8.8; Lampblack, equivalent to Munsell 0.8Y 2.5/0.4		
External dimensions	See the dimensional figures in "External Dimensions" of the "Hardware Manual" (IM 34M06C11-01E)		

¹: Some FA-M3 modules may have a narrower ambient temperature range than 0-55°C. A system incorporating such modules must be used within the narrower ambient temperature range for such modules.

²: For details on conforming modules, see "UL-approved, CE marking and C-Tick mark-compliant Modules" (GS 34M06C11-21E) general specification brochure.

³: The term Overvoltage Category involves prescriptions on resistance to surge voltage reduction due to lightning and has four categories. Overvoltage Category II applies to systems with a rated voltage of 220/230/240 V and applies to electrical appliances, portable devices, etc.

⁴: The term Pollution Degree represents the degree of pollution with foreign matter, solid, liquid or gaseous, that may produce a reduction of dielectric strength or surface resistivity in the operating environment of the equipment. Pollution degree 2 refers to an environment where normally only non-conductive pollution occurs but occasionally temporary conductivity caused by condensation is to be expected.

⁵: F3BU04, F3BU05, F3BU06, F3BU09 and F3BU13 each uses four mounting screws while F3BU16 uses six mounting screws..

⁶: EN61326-2-3 is applicable only to F3CU04-0S and F3CU04-1S.

Power Supply Specifications

Item	Specification					
	F3PU10-0N F3PU10-0S	F3PU20-0N F3PU20-0S	F3PU30-0N F3PU30-0S	F3PU16-0N	F3PU26-0N	F3PU36-0N F3PU36-0S
Supply voltage	100 V to 240 V AC, single phase, 50/60 Hz			24 V DC		
Supply voltage fluctuation range	85 V to 264 V AC, 50/60 Hz ±3 Hz			15.6 V to 31.2 V DC		
Power consumption	35 VA	85 VA	100VA	15.4 W	33.1 W	46.2 W
Inrush current	20 A max. (120 V AC, Ta = 25°C) 45 A max. (240 V AC, Ta = 25°C)			20 A max. (31.2 V DC, Ta = 25°C)		
Rated output voltage	5 V DC					
Rated output current	2.0 A	4.3 A	6.0 A	2.0 A	4.3 A	6.0 A
Allowable momentary power failure time	20 ms					
FAIL-signal contact output	Provided on the front terminal block on the power supply module: contact rating: 24 V DC, 0.3 A (both normally-open and normally-closed terminals available)					
Allowable common mode voltage of FAIL-signal contact	120 V AC or DC or less (between FAIL OUTPUT COM terminal and FG terminal)					
Leakage current	3.5 mA max.			—		
Insulation resistance	5 MΩ or greater at 500 V DC (between external AC terminals and FG terminal)			5 MΩ or greater at 500 V DC (between external DC terminals and FG terminal)		
Dielectric strength	1500 V AC for 1 minute (between external AC terminals and FG terminal)			1500 V AC for 1 minute (between external DC terminals and FG terminal)		

Note: F3PU□□-0S has the same dimensions, internal circuitry and other specifications as its respective F3PU□□-0N counterpart but uses screw size M4.0 instead of M3.5.

■ Functional Specifications

Item	Specification							
	F3SP21	F3SP25	F3SP35	F3SP28-3N	F3SP38-6N	F3SP53-4H	F3SP58-6H	
Control mode	Repetitive computation based on stored programs							
I/O control mode	Refresh method/Direct I/O instructions							
Programming language	Structured ladder language, mnemonic language			Object ladder language				
Number of I/O points	2048 max	4096 max	8192 max (incl. remote I/O)	4096 max	8192 max	4096 max	8192 max	
Number of instructions	Basic instructions	25 types			33 types			
	Application instructions	227 types	307 types		312 types			
Instruction processing speed	Basic instructions	0.18-0.36 μs /instruction	0.12-0.24 μs /instruction	0.09-0.18 μs /instruction	0.045-0.18 μs /instruction		0.0175-0.07 μs /instruction	
	Application instructions	From 0.36 μs /instruction	From 0.36 μs /instruction	From 0.18 μs /instruction	From 0.18 μs /instruction		From 0.07 μs /instruction	
Program size	10K steps (can be written to ROM)	20K steps (can be written to ROM)	100K steps (can be written to ROM)	30K steps (can be written to ROM)	120K steps (can be written to ROM)	56K steps (can be written to ROM)	120K steps (can be written to ROM)	
Number of program blocks	32 max	128 max	1024 max	1024 max				
Sampling trace	No	Yes	Yes	Yes				
Link to personal computer	Yes			Yes				
Scan monitoring time	10 to 200 ms variable			10 to 200 ms variable				
Device	Internal relay	I: 4096 max. (4096 max. for internal and shared relays combined)	I: 8192 max. (8192 max. for internal and shared relays combined)	I: 16384 max. (32768 max. for internal and shared relays combined)	I: 16384 max.	I: 32768 max.	I: 16384 max.	I: 32768 max.
	Shared relay	E: 2048 max. (4096 max. for internal and shared relays combined)	E: 2048 max. (8192 max. for internal and shared relays combined)	E: 2048 max. (16384 max. for internal and shared relays combined)	E: 2048 max.			
	Extended shared relay	E: 2048						
	Link relay	L: 2048	L: 8192	L: 8192	L: 8192	L: 16384	L: 8192	L: 16384
	Special relay	M: 9984						
	Timer	T: 512 max. (512 max. for timers and counters combined)	T: 2048 max. (2048 max. for timers and counters combined)	T: 3072 max. (3072 max. for timers and counters combined)	T: 2048 max. (2048 max. for timers and counters combined)	T: 3072 max. (3072 max. for timers and counters combined)	T: 2048 max. (2048 max. for timers and counters combined)	T: 3072 max. (3072 max. for timers and counters combined)
	Counter	C: 512 max. (512 max. for timers and counters combined)	C: 2048 max. (2048 max. for timers and counters combined)	C: 3072 max. (3072 max. for timers and counters combined)	C: 2048 max. (2048 max. for timers and counters combined)	C: 3072 max. (3072 max. for timers and counters combined)	C: 2048 max. (2048 max. for timers and counters combined)	C: 3072 max. (3072 max. for timers and counters combined)
	Data register	D: 5120 max. (5120 max. for data and shared registers combined)	D: 8192 max. (8192 max. for data and shared registers combined)		D: 16384 max.	D: 32768 max.	D: 16384 max.	D: 32768 max.
	File register	B: 32768						
	Link register	W: 2048	W: 8192		W: 8192	W: 16384	W: 8192	W: 16384
	Special register	Z: 512			Z: 1024			
	Index register	V: 32			V: 256			
	Shared register	R: 1024 max. (5120 max. for data and shared registers combined)	R: 1024 max. (8192 max. for data and shared registers combined)		R: 1024 max.			
Extended shared register	R: 3072 max.			R: 3072 max.				

Item	Specification					
	F3SP28-3S	F3SP38-6S	F3SP53-4S	F3SP58-6S	F3SP59-7S	
Control mode	Repetitive computation based on stored programs					
I/O control mode	Refresh method/Direct I/O instructions					
Programming language	Object ladder language, mnemonic language					
Number of I/O points	4096 max	8192 max	4096 max	8192 max		
Number of instructions	Basic instructions	37 types				
	Application instructions	329 types				
Instruction processing speed	Basic instructions	0.045-0.18 μ s/instruction		0.0175-0.07 μ s/instruction		
	Application instructions	From 0.18 μ s/instruction		From 0.07 μ s/instruction		
Program size	30K steps (can be written to ROM)	120K steps (can be written to ROM)	56K steps (can be written to ROM)	120K steps (can be written to ROM)	254K steps (can be written to ROM)	
Number of program blocks	1024 max					
Sampling trace	Yes					
Link to personal computer	Yes					
Scan monitoring time	10 to 200 ms variable					
Device	Internal relay	I: 16384 max.	I: 32768 max.	I: 16384 max.	I: 32768 max.	I: 65535 max.
	Shared relay	E: 2048 max.				
	Extended shared relay	E: 2048				
	Link relay	L: 8192	L: 16384	L: 8192	L: 16384	
	Special relay	M: 9984				
	Timer	T: 2048 max. (2048 max. for timers and counters combined)	T: 3072 max. (3072 max. for timers and counters combined)	T: 2048 max. (2048 max. for timers and counters combined)	T: 3072 max. (3072 max. for timers and counters combined)	
	Counter	C: 2048 max. (2048 max. for timers and counters combined)	C: 3072 max. (3072 max. for timers and counters combined)	C: 2048 max. (2048 max. for timers and counters combined)	C: 3072 max. (3072 max. for timers and counters combined)	
	Data register	D: 16384 max.	D: 32768 max.	D: 16384 max.	D: 32768 max.	D: 65535 max.
	File register	B: 32768	B: 262144	B: 32768		
	Link register	W: 8192	W: 16384	W: 8192	W: 16384	
	Special register	Z: 1024				
	Index register	V: 256				
	Shared register	R: 1024 max.				
	Extended shared register	R: 3072 max.				

Item	Specification				
	F3SP66-4S	F3SP67-6S	F3SP71-4N	F3SP76-7N	
Control mode	Repetitive computation based on stored programs				
I/O control mode	Refresh method/Direct I/O instructions				
Programming language	Object ladder language				
Number of I/O points	4096 max	8192 max	4096 max	8192 max	
Number of instructions	Basic instructions	37 types		37 types	
	Application instructions	389 types		389 types	
Instruction processing speed	Basic instructions	0.0175-0.07 μ s/instruction		From 0.00375 μ s/instruction	
	Application instructions	From 0.07 μ s/instruction		From 0.0075 μ s/instruction	
Program size	56K steps (can be written to ROM)	120K steps (can be written to ROM)	60K steps (can be written to ROM)	260K steps (can be written to ROM)	
Number of program blocks	1024 max				
Sampling trace	Yes				
Link to personal computer	Yes		Yes (by Ethernet only)		
Scan monitoring time	10 to 200 ms variable				
Device	Internal relay	I: 16384 max.	I: 32768 max.	I: 16384 max.	I: 65535 max.
	Shared relay	E: 2048 max.			
	Extended shared relay	E: 2048			
	Link relay	L: 8192	L: 16384	L: 8192	L: 16384
	Special relay	M: 9984			
	Timer	T: 2048 max. (2048 max. for timers and counters combined)	T: 3072 max. (3072 max. for timers and counters combined)	T: 2048 max. (2048 max. for timers and counters combined)	T: 3072 max. (3072 max. for timers and counters combined)
	Counter	C: 2048 max. (2048 max. for timers and counters combined)	C: 3072 max. (3072 max. for timers and counters combined)	C: 2048 max. (2048 max. for timers and counters combined)	C: 3072 max. (3072 max. for timers and counters combined)
	Data register	D: 16384 max.	D: 32768 max.	D: 16384 max.	D: 65535 max.
	File register	B: 32768	B: 262144	B: 32768	B: 262144
	Link register	W: 8192	W: 16384	W: 8192	W: 16384
	Special register	Z: 1024			
	Index register	V: 256			
	Shared register	R: 1024 max.			
	Extended shared register	R: 3072 max.			

■ Sequence CPU Module Specifications for FA-M3 Value *2

Item		Specification	
Power supply specifications	Power supply	100 V to 240 V AC, single phase, 50/60Hz	
	Power supply fluctuation range	85 V to 264 V AC, 50/60Hz ±3 Hz	
	Power consumption	35 VA	
	Inrush current	20 A max. (120 V AC, Ta = 25°C), 45 A max. (240 V AC, Ta = 25°C)	
	Rated output voltage	5 V DC	
	Rated output current	2.0 A	
	Insulation resistance	5 MΩ or greater at 500 V DC (between external AC terminals and FG terminal)	
	Withstand voltage	1500 V AC for 1 minute (between external AC terminals and FG terminal)	
	FAIL-signal contact output	Provided on the front terminal block on the power supply module; contact rating: 24 V DC, 0.3 A (both normally-open and normally-closed terminals available)	
	Allowable common-mode voltage of FAIL-signal contact	120 V AC or DC or less (between FAIL OUTPUT COM terminal and FG terminal)	
	Leakage current	3.5 mA max.	
	Allowable momentary power failure time	20 ms	
	Performance Specifications	Control mode	Repetitive computation based on stored programs
I/O control mode		Refresh method/Direct input-output instructions	
Programming language		Structured ladder language, mnemonic language	
Number of instructions		Basic instructions	25 types
		Application instructions	227 types
Instruction processing speed		Basic instructions	0.18 to 0.36 μs/instruction
		Application instructions	From 0.36 μs/instruction
Program size		5K steps (can be written to ROM)	
Number of I/O points		2048 max.	
Number of program blocks		32 max.	
Sampling trace		No	
Link to personal computer		Yes	
Scan monitoring time		10 to 200 ms variable	
Device		Internal relay	I: 4096 max.
		Shared relay	—
		Extended shared relay	—
		Link relay	L: 2048
		Special relay	M: 2048
		Timer	T: 512 max. (512 max. for timers and counters combined)
		Counter	C: 512 max. (512 max. for timers and counters combined)
		Data register	D: 5120 max.
	File register	—	
	Link register	W: 2048	
	Special register	Z: 512	
	Index register	V: 32	
	Shared register	—	
Extended shared register	—		

*1: The F3SP05-0P is a dedicated sequence CPU module for the FA-M3 Value (F3SC21-1N).

*2: FA-M3 Value shares the common specifications given on page 6.

■ Sequence CPU Module Specifications for FA-M3 Value II ^{*3}

Item		Specification	
		F3SP08-0P ^{*1} /F3SP08-SP ^{*2}	
Power supply specifications	Power supply	100 V to 240 V AC, single phase, 50/60Hz	
	Power supply fluctuation range	85 V to 264 V AC, 50/60Hz ±3 Hz	
	Power consumption	35 VA	
	Inrush current	20 A max. (120 V AC, Ta = 25°C), 45 A max. (240 V AC, Ta = 25°C)	
	Rated output voltage	5 V DC	
	Rated output current	2.0 A	
	Insulation resistance	5 MΩ or greater at 500 V DC (between external AC terminals and FG terminal)	
	Withstand voltage	1500 V AC for 1 minute (between external AC terminals and FG terminal)	
	FAIL-signal contact output	Provided on the front terminal block on the power supply module; contact rating: 24 V DC, 0.3 A (both normally-open and normally-closed terminals available)	
	Allowable common-mode voltage of FAIL-signal contact	120 V AC or DC or less (between FAIL OUTPUT COM terminal and FG terminal)	
	Leakage current	3.5 mA max.	
	Allowable momentary power failure time	20 ms	
Performance specifications	Control mode	Repetitive computation based on stored programs	
	I/O control mode	Refresh method/Direct I/O instructions	
	Programming language	Structured ladder language, mnemonic language	
	Number of instructions	Basic instructions	25 types
		Application instructions	227 types
	Instruction processing speed	Basic instructions	0.18 to 0.36 μs/instruction
		Application instructions	From 0.36 μs/instruction
	Program size	10 K steps (can be written to ROM)	
	Number of I/O points	2048 points max.	
	Number of program blocks	32 max.	
	Sampling trace	No	
	Link to personal computer	Yes	
	Scan monitoring time	10 to 200 ms variable	
	Device	Internal relay	I: 4096 max.
		Shared relay	—
		Extended shared relay	—
		Link relay	L: 2048
		Special relay	M: 2048
		Timer	T: 512 max. (512 max. for timers and counters combined)
		Counter	C: 512 max. (512 max. for timers and counters combined)
		Data register	D: 5120 max.
		File register	—
		Link register	W: 2048
Special register		Z: 512	
Index register		V: 32	
Shared register	—		
Extended shared register	—		

*1: The F3SP08-0P is a dedicated sequence CPU module for the FA-M3 Value II (F3SC22-□□).

*2: The F3SP08-SP is a dedicated sequence CPU module for the FA-M3 Value II (F3SC23-□□).

*3: FA-M3 Value II shares the common specifications given on page 6.

*Note:

F3SP08-0P and F3SP08-SP have exactly the same dimensions, internal circuitry and other characteristics, except that F3SP08-0P uses M3.5-screw terminals while F3SP08-SP uses M4-screw terminals.

■ Ladder Sequence Basic Instructions

FUNC No	Instruction	Mnemonic	Symbol	Function	Applicable CPU			
					F3SP05 F3SP08 F3SP21	F3SP25 F3SP35	F3SP28-3N F3SP38-6N F3SP53-4H F3SP58-6H	F3SP28-3S F3SP38-6S F3SP53-4S F3SP58-6S F3SP59-7S F3SP66-4S F3SP67-6S F3SP71-4N F3SP76-7N
—	Load	LD		Starts a logic operation (contact a).	●	●	●	●
—	Load Not	LDN		Starts a logic NOT operation (contact b).	●	●	●	●
—	And	AND		Performs an AND (serial contact a) connection.	●	●	●	●
—	And Not	ANDN		Performs an AND NOT (serial contact b) connection.	●	●	●	●
—	Or	OR		Performs an OR (parallel contact a) connection.	●	●	●	●
—	Or Not	ORN		Performs an OR NOT (parallel contact b) connection.	●	●	●	●
—	And Load	ANDLD		Performs an AND with the preceding condition.	●	●	●	●
—	Or Load	ORLD		Performs an OR with the preceding condition.	●	●	●	●
—	Out	OUT		Generates a relay output.	●	●	●	●
07	Out Not	OUTN		Generates a NOT output.	●	●	●	●
—	Push	PUSH		Starts a branch.	●	●	●	●
—	Slack	STCRD		Branch.	●	●	●	●
—	Pop	POP		Terminates a branch.	●	●	●	●
01 / 01P	Set	SET		Set a device.	●	●	●	●
02 / 02P	Reset	RST		Resets a device.	●	●	●	●
—	Timer	TIM		Count-down timer.	●	●	●	●
—	Counter	CNT		Count-down counter.	●	●	●	●
03	Differential Up	DIFU		Causes a relay to turn on for 1 scan on the rising edge of the input signal (result of logical operation).	●	●	●	●
04	Differential Down	DIFD		Causes a relay to turn on for 1 scan on the falling edge of the input signal (result of logical operation).	●	●	●	●
05	Interlock	IL		Starts interlock.	●	●	●	●
06	Interlock Clear	ILC		Resets interlock.	●	●	●	●
00	Nop	NOP		Does nothing.	●	●	●	●
999	End	END		Terminates a scan.	●	●	●	●
301	Load Differential Up	LDU		Causes the result signal of a logical operation to turn on for 1 scan on the rising edge of the signal of a specified device.	—	—	●	●
302	Load Differential Down	LDD		Causes the result signal of a logical operation to turn on for 1 scan on the falling edge of the signal of a specified device.	—	—	●	●
303	Logical Differential Up	UP		Causes the result signal of a logical operation to turn on for 1 scan on the rising edge of the input signal (result of logical operation).	—	—	●	●
304	Logical Differential Down	DWN		Causes the result signal of a logical operation to turn on for 1 scan on the falling edge of the input signal (result of logical operation).	—	—	●	●
305	Logical Differential Up Using Specified Device	UPX		Causes the result signal of a logical operation to turn on for 1 scan on the rising edge of the input signal (result of logical operation). A specified device is used for differential operation.	—	—	●	●
306	Logical Differential Down Using Specified Device	DWNX		Causes the result signal of a logical operation to turn on for 1 scan on the falling edge of the input signal (result of logical operation). A specified device is used for differential operation.	—	—	●	●
307	Inverter	INV		Outputs inverted input signal (result of logical operation).	—	—	●	●
308	Flip-Flop	FF		Causes a relay to invert on every rising edge of an input signal.	—	—	●	●
311	Load Specified Bit	LDW		Outputs the status of a specified bit of a 16-bit data item as contact a.	—	—	—	●
311L	Load Specified Bit Long	LDW L		Outputs the status of a specified bit of a 32-bit data item as contact a.	—	—	—	●
312 / 312P	Out Specified Bit	OUTW		Outputs the result of the logical operations performed so far to a specified bit of a 16-bit data item.	—	—	—	●
312L / 312LP	Out Specified Bit Long	OUTW L		Outputs the result of the logical operations performed so far to a specified bit of a 32-bit data item.	—	—	—	●
313 / 313P	Set Specified Bit	SETW		Sets the specified bit of a 16-bit data item to ON.	—	—	—	●
313L / 313LP	Set Specified Bit Long	SETW L		Sets the specified bit of a 32-bit data item to ON.	—	—	—	●
314 / 314P	Reset Specified Bit	RSTW		Sets the specified bit of a 16-bit data item to OFF.	—	—	—	●
314L / 314LP	Reset Specified Bit Long	RSTW L		Sets the specified bit of a 32-bit data item to OFF.	—	—	—	●

Note: An instruction indicated with two FUNC Nos. can be either executed one or more times while its input condition is ON or executed only once when its input condition is ON (pulse instruction).*

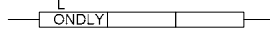
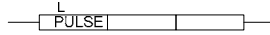
FUNC No	Instruction	Mnemonic	Symbol	Function	Applicable CPU
					F3SP71-4N F3SP76-7N
—	Off Delay	OFDLY L		Outputs OFF-delay timer operation result for a specified device	—
—	On Delay	ONDLY L		Outputs ON-delay timer operation result for a specified device	—
—	Pulse	PULSE L		Outputs pulse timer operation result for a specified device	—

■ Ladder Sequence Application Instructions

Classification	FUNC No.	Instruction	Processing Unit	Mnemonic	Symbol	Function	Applicable CPU				
							F3SP05 F3SP08 F3SP21	F3SP25 F3SP35	F3SP28-3N F3SP38-6N F3SP53-4H F3SP58-6H	F3SP28-3S F3SP38-6S F3SP53-4S F3SP58-6S F3SP59-7S F3SP66-4S F3SP67-6S F3SP71-4N F3SP76-7N	
Comparison	10	Compare	=	16 bits	CMP		Compares 1-word data.	•	•	•	•
			< >	16 bits				•	•	•	•
			>	16 bits				•	•	•	•
			> =	16 bits				•	•	•	•
			<	16 bits				•	•	•	•
			< =	16 bits				•	•	•	•
	10L	Compare Long	=	32 bits	CMP L		Compares 2-word data.	•	•	•	•
			< >	32 bits				•	•	•	•
			>	32 bits				•	•	•	•
			> =	32 bits				•	•	•	•
			<	32 bits				•	•	•	•
			< =	32 bits				•	•	•	•
	904	Compare Float	=	32 bits	FCMP		Compares floating point data.	—	•	•	•
			< >	32 bits				—	•	•	•
			>	32 bits				—	•	•	•
			> =	32 bits				—	•	•	•
			<	32 bits				—	•	•	•
			< =	32 bits				—	•	•	•
	111/111P	Table Compare	16 bits	BCMP		Compares 1-word data against range table.	•	•	•	•	
	111L/111LP	Table Compare Long	32 bits	BCMP L		Compares 2-word data against range table.	•	•	•	•	
	919/919P	Table Compare Float	32 bits	FBCP L		Compares floating-point data against range table.	•	•	•	•	
112/112P	Table Search	16 bits	TSRCH		Searches for 1-word data in table.	•	•	•	•		
112L/112LP	Table Search Long	32 bits	TSRCH L		Searches for 2-word data in table.	•	•	•	•		
Arithmetic	20 /20P	Add	16 bits	CAL		Adds 1-word data.	•	•	•	•	
		Subtract	16 bits			Subtracts 1-word data.	•	•	•	•	
		Multiply	16 bits			Multiplies 1-word data.	•	•	•	•	
		Divide	16 bits			Divides 1-word data.	•	•	•	•	
	20L /20LP	Add Long	32 bits	CAL L		Adds 2-word data.	•	•	•	•	
		Subtract Long	32 bits			Subtracts 2-word data.	•	•	•	•	
		Multiply Long	32 bits			Multiplies 2-word data.	•	•	•	•	
		Divide Long	32 bits			Divides 2-word data.	•	•	•	•	
	903/903P	Add Float	32 bits	FCAL L		Adds floating-point data.	—	•	•	•	
		Subtract Float	32 bits			Subtracts floating-point data.	—	•	•	•	
		Multiply Float	32 bits			Multiplies floating-point data.	—	•	•	•	
		Divide Float	32 bits			Divides floating-point data.	—	•	•	•	

Note: An instruction indicated with two FUNC Nos. can be either executed one or more times while its input condition is ON or executed only once when its input condition is ON (pulse instruction).

Classification	FUNC No.	Instruction	Processing Unit	Mnemonic	Symbol	Function	Applicable CPU			
							F3SP05 F3SP08 F3SP21	F3SP25 F3SP35	F3SP28-3N F3SP38-6N F3SP53-4H F3SP58-6H	F3SP28-3S F3SP38-6S F3SP53-4S F3SP58-6S F3SP59-7S F3SP66-4S F3SP67-6S F3SP71-4N F3SP76-7N
Arithmetic (cont.)	120/120P	Increment	16 bits	INC		Adds 1 to 1-word data.	●	●	●	●
	120L/120LP	Increment Long	32 bits	INC L		Adds 1 to 2-word data.	●	●	●	●
	121/121P	Decrement	16 bits	DEC		Subtracts 1 from 1-word data.	●	●	●	●
	121L/121LP	Decrement Long	32 bits	DEC L		Subtracts 1 from 2-word data.	●	●	●	●
	122/122P	Square Root	16 bits	SQR		Computes square root of 1-word data.	●	●	●	●
	122L/122LP	Square Root Long	32 bits	SQR L		Computes square root of 2-word data.	●	●	●	●
	915/915P	Square Root Float	32 bits	FSQR		Computes square root of floating-point data.	—	●	●	●
	907/907P	SIN	32 bits	FSIN L		Computes the sine of a radian angle as a floating-point (SIN) number.	—	●	●	●
	908/908P	COS	32 bits	FCOS L		Computes the cosine of a radian angle as a floating-point (COS) number.	—	●	●	●
	909/909P	TAN	32 bits	FTAN L		Computes the tangent of a radian angle as a floating-point (TAN) number.	—	●	●	●
	910/910P	SIN ⁻¹	32 bits	FASIN L		Computes the arc sine of a floating-point number in radians (SIN ⁻¹).	—	●	●	●
	911/911P	COS ⁻¹	32 bits	FACOS L		Computes the arc cosine of a floating-point number in radians (COS ⁻¹).	—	●	●	●
	912/912P	TAN ⁻¹	32 bits	FATAN L		Computes the arc tangent of a floating-point number in radians (TAN ⁻¹).	—	●	●	●
	913/908P	LOG	32 bits	FLOG L		Computes the logarithm of floating-point data.	—	●	●	●
914/914P	EXP	32 bits	FEXP L		Computes the exponential of floating-point data.	—	●	●	●	
Logical	20 /20P	Logical AND	16 bits	CAL		Performs AND operation on 1-word data.	●	●	●	●
		Logical OR	16 bits			Performs OR operation on 1-word data.	●	●	●	●
		Logical XOR	16 bits			Performs XOR operation on 1-word data.	●	●	●	●
		Logical NXOR	16 bits			Performs NXOR operation on 1-word data.	●	●	●	●
	20L /20LP	Logical AND Long	32 bits	CAL L		Performs AND operation on 2-word data.	●	●	●	●
		Logical OR Long	32 bits			Performs OR operation on 2-word data.	●	●	●	●
		Logical XOR Long	32 bits			Performs XOR operation on 2-word data.	●	●	●	●
		Logical NXOR Long	32 bits			Performs NXOR operation on 2-word data.	●	●	●	●
	21 /21P	Two's Complement	16 bits	NEG		Calculate two's complement of 1-word data (inverts sign).	●	●	●	●
	21L /21LP	Two's Complement Long	32 bits	NEG L		Calculate two's complement of 2-word data (inverts sign).	●	●	●	●
22 /22P	NOT	16 bits	NOT		Inverts all bits of 1-word data.	●	●	●	●	
22L /22LP	NOT Long	32 bits	NOT L		Inverts all bits of 2-word data.	●	●	●	●	
Rotate	30 /30P	Right Rotate	16 bits	RROT		Rotates 1 word right by 1 bit.	●	●	●	●
	30L /30LP	Right Rotate Long	32 bits	RROT L		Rotates 2 words right by 1 bit	●	●	●	●
	130 /130P	Right Rotate with Carry	16 bits	RROTC		Rotates 1 word right by 1 bit (with carry).	●	●	●	●
	130L /130LP	Right Rotate with Carry Long	32 bits	RROTC L		Rotates 2 words right by 1 bit (with carry).	●	●	●	●
	31 /31P	Left Rotate	16 bits	LROT		Rotates 1 word left by 1 bit.	●	●	●	●
	31L /31LP	Left Rotate Long	32 bits	LROT L		Rotates 2 words left by 1 bit.	●	●	●	●
	131/131P	Left Rotate with Carry	16 bits	LROTC		Rotates 1 words left by 1 bit (with carry).	●	●	●	●
	131L/131LP	Left Rotate with Carry Long	32 bits	LROTC L		Rotates 2 words left by 1 bit (with carry).	●	●	●	●

Note: An instruction indicated with two FUNC Nos. can be either executed one or more times while its input condition is ON or executed only once when its input condition is ON (pulse instruction).

Classification	FUNC No.	Instruction	Processing Unit	Mnemonic	Symbol	Function	Applicable CPU			
							F3SP05 F3SP08 F3SP21	F3SP25 F3SP35	F3SP28-3N F3SP38-6N F3SP53-4H F3SP58-6H	F3SP28-3S F3SP38-6S F3SP53-4S F3SP58-6S F3SP59-7S F3SP66-4S F3SP67-6S F3SP71-4N F3SP76-7N
Shift	32 /32P	Right Shift	16 bits	RSFT		Shifts 1 word right by 1 bit.	●	●	●	●
	32L /32LP	Right Shift Long	32 bits	RSFT L		Shifts 2 words right by 1 bit.	●	●	●	●
	132/132P	Right Shift m-bit Data by n bits	—	RSFTN		Shifts data of specified bit length right by a specified number of bits.	●	●	●	●
	33 /33P	Left Shift	16 bits	LSFT		Shifts 1 word left by 1 bit.	●	●	●	●
	33L /33LP	Left Shift Long	32 bits	LSFT L		Shifts 2 words left by 1 bit.	●	●	●	●
	133/133P	Left Shift m-bit Data by n bits	—	LSFTN		Shifts data of specified bit length left by a specified number of bits.	●	●	●	●
	34	Shift Register	—	SFTR		Shifts data of specified bit length left and right by 1-bit position.	○	○	○	○
Data Transfer	40 /40P	Move	16 bits	MOV		Moves 1-word data.	●	●	●	●
	40L /40LP	Move Long	32 bits	MOV L		Moves 2-word data.	●	●	●	●
	41 /41P	Partial Move	16 bits	PMOV		Moves specified part of 1-word data.	●	●	●	●
	42 /42P	Block Move	16 bits	BMOV		Moves n-word data.	●	●	●	●
	43 /43P	Block Set	16 bits	BSET		Sets data into n words.	●	●	●	●
	44 /44P	Right word Shift	16 bits	RWS		Shifts word right.	●	●	●	●
	45 /45P	Left Word Shift	16 bits	LWS		Shifts word left.	●	●	●	●
	46 /46P	Indexed Move	16 bits	IXMOV		Moves 1-word data with index.	●	●	●	●
46L /46LP	Indexed Move Long	32 bits	IXMOV L		Moves 2-word data with index.	●	●	●	●	
Data Transfer	47 /47P	Exchange	16 bits	XCHG		Exchanges 1-word data.	●	●	●	●
	47L /47LP	Exchange Long	32 bits	XCHG L		Exchanges 2-word data.	●	●	●	●
	140/140P	Negated Move	16 bits	NMOV		Moves 1-word data with inversion.	●	●	●	●
	140L/140LP	Negated Move Long-word	32 bits	NMOV L		Moves 2-word data with inversion.	●	●	●	●
	141/141P	Extended Partial Move	16 bits max.	PMOVX		Moves specified part of 1-word data.	●	●	●	●
	142/142P	Bit Move	16 bits	BITM		Moves 1 bit.	●	●	●	●
	143/143P	Digit Move	16 bits	DGTM		Moves a specified digit of 1-word data.	●	●	●	●
Data Processing	50 /50P	FIFO Read	16 bits	FIFRD		Reads FIFO table.	●	●	●	●
	51 /51P	FIFO Write	16 bits	FIFWR		Writes FIFO table.	●	●	●	●
	52 /52P	Binary Conversion	16 bits	BIN		Converts 1-word data from BCD code to BIN code.	●	●	●	●
	52L /52LP	Binary Conversion Long	32 bits	BIN L		Converts 2-word data from BCD code to BIN code.	●	●	●	●
	53 /53P	BCD Conversion	16 bits	BCD		Converts 1-word data from BIN code to BCD code.	●	●	●	●
	53L /53LP	BCD Conversion Long	32 bits	BCD L		Converts 2-word data from BIN code to BCD code.	●	●	●	●
	916/916P	Float to BCD	32 bits	FBCD L		Converts floating-point data to BCD.	—	●	●	●
	917/917P	BCD to Float	32 bits	BCDF L		Converts BCD to floating-point data.	—	●	●	●
	901/901P	Integer to Float	16 bits	ITOF		Converts 1-word integer to floating-point data.	—	●	●	●
	901L/901LP	Long Integer to Float	32 bits	ITOF L		Converts 2-word integer to floating-point data.	—	●	●	●
	902/902P	Float to Integer	16 bits	FTOI		Converts floating-point data to 1-word integer.	—	●	●	●
902L/902LP	Float to Long Integer	32 bits	FTOI L		Converts floating-point data to 2-word integer.	—	●	●	●	

Note: An instruction indicated with two FUNC Nos. can be either executed one or more times while its input condition is ON or executed only once when its input condition is ON (pulse instruction).
An instruction indicated with "○" is executed only once when its input condition is ON

Classification	FUNC No.	Instruction	Processing Unit	Mnemonic	Symbol	Function	Applicable CPU			
							F3SP05 F3SP08 F3SP21	F3SP25 F3SP35	F3SP28-3N F3SP38-6N F3SP53-4H F3SP58-6H	F3SP28-3S F3SP38-6S F3SP53-4S F3SP58-6S F3SP59-7S F3SP66-4S F3SP67-6S F3SP71-4N F3SP76-7N
Data Processing (cont.)	905/905P	Convert Degree to Radian	32 bits	FRAD L		Converts degree (floating-point) data to radian (floating-point) data.	—	●	●	●
	906/906P	Convert Radian to Degree	32 bits	FDEG L		Converts radian (floating-point) data to degree (floating-point) data.	—	●	●	●
	54 /54P	7-Segment Decoder	16 bits	SEG		Decodes to 7-segment LED data.	●	●	●	●
	55 /55P	Convert ASCII	16 bits	ASC		Converts to ASCII data.	●	●	●	●
	56 /56P	Bit set	16 bits	BITS		Sets bit of 1-word data.	●	●	●	●
	56L /56LP	Bit Set Long	32 bits	BITS L		Sets bit of 2-word data.	●	●	●	●
	57 /57P	Bit Reset	16 bits	BITR		Resets bit of 1-word data.	●	●	●	●
	57L /57LP	Bit Reset Long	32 bits	BITR L		Resets bit of 2-word data.	●	●	●	●
	151/151P	Carry Set	—	CSET		Sets carry flag.	●	●	●	●
	152/152P	Carry Reset	—	CRST		Resets carry flag.	●	●	●	●
	153/153P	Distribute Data	16 bits	DIST		Distributes 1-word data into 4-bit segments.	●	●	●	●
	153L/153LP	Distribute Data Long	32 bits	DIST L		Distributes 2-word data into 4-bit segments.	●	●	●	●
	154/154P	Unit Data	16 bits	UNIT		Extracts 4-bit data from 4-word data.	●	●	●	●
	154L/154LP	Unit Data Long	32 bits	UNIT L		Extracts 4-bit data from 8-word data.	●	●	●	●
	155/155P	Decode	16 bits	DECO		Decodes 8-bit data into 256-bit data.	●	●	●	●
	156/156P	Encode	16 bits	ENCO		Decodes 256-bit data into 8-bit data.	●	●	●	●
	157/157P	Bit Counter	16 bits	BCNT		1-word bit counter	●	●	●	●
	157L/157LP	Bit Counter Long	32 bits	BCNT L		2-word bit counter	●	●	●	●
	158/158P	Approximate Broken Line	16 bits	APR		Approximates 1-word line segment.	●	●	●	●
	158L/158LP	Approximate Broken Line Long	32 bits	APR L		Approximates 2-word line segment.	●	●	●	●
918/918P	Float Approximate Broken Line	32 bits	FAPR L		Approximates floating-point line segment.	—	●	●	●	
951/951P	Extend Sign	32 bits	SIGN L		Provides sign extension.	—	●	●	●	
Refresh	60 /60P	Direct Refresh	16 bits	DREF		Refreshes I/O relay.	●	●	●	●
Program Control	61 /61P	Jump	—	JMP		Causes a jump to a specified location.	●	●	●	●
	62 /62P	Subroutine Call	—	CALL		Calls a subroutine.	●	●	●	●
	63	Subroutine Entry	—	SUB		Begins a subroutine.	●	●	●	●
	64	Subroutine Return	—	RET		Ends a subroutine.	●	●	●	●
	65	Interrupt	—	INTP		Starts interrupt processing.	●	●	●	●
	66	Interrupt Return	—	IRET		Returns from interrupt processing.	●	●	●	●
	67	Disable Interrupt	—	DI		Disables interrupts.	●	●	●	●
	68	Enable Interrupt	—	EI		Enables interrupts.	●	●	●	●
	69 /69P	Activate Block	—	ACT		Activates a block.	●	●	●	●
	70 /70P	Inactivate Block	—	INACT		Inactivates a block.	●	●	●	●
	71 /71P	Activate Sensor Control Block	—	CBACT		Activates a sensor control block.	—	—	●	●
	72 /72P	Inactivate Sensor Control Block	—	CBINA		Inactivates a sensor control block.	—	—	●	●
	73	Disable Sensor Control Block	—	CBD		Disables a sensor control block.	—	—	●	●
	74	Enable Sensor Control Block	—	CBE		Enables a sensor control block.	—	—	●	●

Note: An instruction indicated with two FUNC Nos. can be either executed one or more times while its input condition is ON or executed only once when its input condition is ON (pulse instruction).

Classification	FUNC No.	Instruction	Processing Unit	Mnemonic	Symbol	Function	Applicable CPU			
							F3SP05 F3SP08 F3SP21	F3SP25 F3SP35	F3SP28-3N F3SP38-6N F3SP53-4H F3SP58-6H	F3SP28-3S F3SP38-6S F3SP53-4S F3SP58-6S F3SP59-7S F3SP66-4S F3SP67-6S F3SP71-4N F3SP76-7N
Program Control (cont.)	160	For Loop	—	FOR	FOR	Begins a loop.	●	●	●	●
	161	Next Loop	—	NEXT	NEXT	Ends a loop.	●	●	●	●
	162	Break Loop	—	BRK	BRK	Breaks a FOR-NEXT loop.	●	●	●	●
	280P	Signal to BASIC	—	SIG	SIG	Signals an interrupt to BASIC.	○	○	○	○
Special Module	81 /81P	Read	16 bits	READ	READ	Reads a special module in 1-word units.	●	●	●	●
	81L /81LP	Read Long	32 bits	READ L	L READ	Reads a special module in 2-word units.	●	●	●	●
	82 /82P	Write	16 bits	WRITE	WRITE	Writes a special module in 1-word units.	●	●	●	●
	82L /82LP	Write Long	32 bits	WRITE L	L WRITE	Writes a special module in 2-word units.	●	●	●	●
	83 /83P	High-speed Read	16 bits	HRD	HRD	Reads a special module in 1-word units at high speed.	●	●	●	●
	83L /83LP	High-speed Read Long	32 bits	HRD L	L HRD	Reads a special module in 2-word units at high speed.	●	●	●	●
	84 /84P	High-speed Write	16 bits	HWR	HWR	Writes a special module in 1-word units at high speed.	●	●	●	●
84L /84LP	High-speed Write Long	32 bits	HWR L	L HWR	Writes a special module in 2-word units at high speed.	●	●	●	●	
String Manipulation	931/931P	String to Number	16 bits	VAL	VAL	Converts character string data into numeric data.	—	●	●	●
	931L/931LP	String to Long Number	32 bits	VAL L	L VAL	Converts character string data into long-word numeric data.	—	●	●	●
	932/932P	Number to String	16 bits	STR	STR	Converts numeric data into character string data.	—	●	●	●
	932L/932LP	Long Number to String	32 bits	STR L	L STR	Converts long-word numeric data into character string data.	—	●	●	●
	933/933P	String Chain	8 bits	SCHN	SCHN	Concatenates character strings.	—	●	●	●
	934/934P	String Move	8 bits	SMOV L	L SMOV	Moves character strings.	—	●	●	●
	935/935P	String Length Count	8 bits	SLEN	SLEN	Counts the length of a character string.	—	●	●	●
	936/936P	Compare String	8 bits	SCMP	SCMP	Compares character strings.	—	●	●	●
	937/937P	String Middle	8 bits	SMID	SMID	Extracts a substring from a character string.	—	●	●	●
	938/938P	String Left	8 bits	SLFT	SLFT	Extracts a substring from the left of a character string.	—	●	●	●
	939/939P	String Right	8 bits	SRIT	SRIT	Extracts a substring from the right of a character string.	—	●	●	●
940/940P	String Search	8 bits	SIST	SIST	Searches for a character string.	—	●	●	●	
Structure and Macro	986	Structure Pointer Declaration	—	STRCT	STRCT	Declares the type of structures to be passed.	—	—	—	●
	987	Structure Move	—	STMOV	STMOV	Moves structures.	—	—	—	●
	982/982P	Structure Macro Instruction Call	1/16	SCALL	S cccccccc	Executes a registered structure macro instruction.	—	—	—	●
	996/996P	Macro Call	1/16/32	MCALL	M cccccccc	Transfers control to a specified macro instruction.	—	●	●	●
	995/995P	Parameter	1/16/32	PARA	PARA	Passes parameters to a macro instruction or an input macro.	—	●	●	●
	998	Macro Return	—	MRET	MRET	Designates the end of a macro instruction, input macro instruction, or structure macro instruction.	—	●	●	●
	981	Input Macro Instruction Call	1/16/32	NCALL	N cccccccc	Executes a registered macro instruction.	—	—	—	●
	309/309P	Output of Input Macro	1/16	NMOUT	NMOUT	Specifies the logical operation result of an input macro instruction.	—	—	—	●

Note: An instruction indicated with two FUNC Nos. can be either executed one or more times while its input condition is ON or executed only once when its input condition is ON (pulse instruction).
An instruction indicated with "○" is executed only once when its input condition is ON

Classification	FUNC No.	Instruction	Processing Unit	Mnemonic	Symbol	Function	Applicable CPU			
							F3SP05 F3SP08 F3SP21	F3SP25 F3SP35	F3SP28-3N F3SP38-6N F3SP53-4H F3SP58-6H	F3SP28-3S F3SP38-6S F3SP53-4S F3SP58-6S F3SP59-7S F3SP66-4S F3SP67-6S F3SP71-4N F3SP76-7N
Indirect Specification	510/510P	Indirect Address Set	3 bits	SET@	— SET@	Stores the value representing a device address as three-word data.	—	—	—	●
	511/511P	Indirect Address Add	2 bits	ADD@	— L ADD@	Adds a long-word value to an address and stores the result as 3-word data.	—	—	—	●
	512/512P	Indirect Address Move	3 bits	MOV@	— MOV@	Transfers an indirect address stored as 3-word data.	—	—	—	●
Watchdog	85 /85P	Refresh Watchdog Timer	—	WDT	— WDT	Refreshes a watchdog timer.	●	●	●	●
Free Run Timer	186/186P	Read Free Run Timer	16 bits	FTIMR	— FTIMR	Reads free-run timer of CPU module	—	—	●	●
Trace	181/181P	Sampling Trace	1 bit 16 bits	TRC	— TRC	Acquires sampling trace data.	—	●	●	●
User Log	961/961P	Save User Log	8 bits	ULOG	— ULOG	Stores user log.	●	●	●	●
	962/962P	Read User Log	8 bits	ULOGR	— ULOGR	Reads user log.	●	●	●	●
	963/963P	Clear User Log	8 bits	UCLR	— UCLR	Clears user log.	●	●	●	●
Date and Time	520P	Set Date	3 bits	DATE	— DATE	Sets the date of the sequence CPU module.	—	—	—	○
	521P	Set Time	3 bits	TIME	— TIME	Sets the time of the sequence CPU module.	—	—	—	○
	522P	Set Date String	8 bits	SDATE	— SDATE	Sets the date of the sequence CPU module using a specified date string.	—	—	—	○
	523P	Set Time String	8 bits	STIME	— STIME	Sets the time of the sequence CPU module using a specified time string.	—	—	—	○

Note: An instruction indicated with two FUNC Nos. can be either executed one or more times while its input condition is ON or executed only once when its input condition is ON (pulse instruction).
An instruction indicated with "○" is executed only once when its input condition is ON.

■ Ladder Sequence Continuous Type Application Instructions

Classification	FUNC No.	Instruction	Processing Unit	Mnemonic	Symbol	Function	Applicable CPU
							F3SP66-4S F3SP67-6S F3SP71-4N F3SP76-7N
Disk Operation	—	Mount Memory Card	—	MOUNT		Mounts a memory card.	●
	—	Unmount Memory Card	—	UNMOUNT		Unmounts a memory card.	●
	—	Format Disk	—	FORMAT		Formats a memory card or RAM disk.	●
	—	Disk Info	—	DISKINFO		Gets information about a specified disk.	●
File Access	—	Open File	16 bits	FOPEN		Opens a file.	●
	—	Close File	16 bits	FCLOSE		Closes a file.	●
	—	Read File Line	8 bits	FGETS		Reads one line from a file.	●
	—	Write File Line	8 bits	FPUTS		Writes one line to a file.	●
	—	Read File Block	8 bits	FREAD		Reads data of specified size from a file.	●
	—	Write File Block	8 bits	FWRITE		Writes data of specified size to a file.	●
	—	File Seek	8 bits	FSEEK		Moves the file pointer of a file.	●
	—	File Text Search	8 bits	FSEARCHT		Finds a specified string in a file.	●
	—	File Binary Search	8 bits	FSEARCHB		Finds specified binary data in a file.	●
	—	Convert CSV File to Device	—	F2DCSV		Converts a CSV formatted file into device data.	●
	—	Convert Device to CSV File	—	D2FCSV		Converts device data into a CSV formatted file.	●
	—	Convert Binary File to Device	—	F2DBIN		Converts a binary file into device data.	●
	—	Convert Device to Binary File	—	D2FBIN		Converts device data into a binary file.	●
	File Operation	—	Copy File	—	FCOPY		Copies one or more files.
—		Move File	—	FMOVE		Moves one or more files.	●
—		Delete File	—	FDEL		Deletes one or more files.	●
—		Make Directory	—	FMKDIR		Creates a directory.	●
—		Remove Directory	—	FRMDIR		Deletes a directory.	●
—		Rename File	—	FREN		Renames a file or directory.	●
—		File Status	—	FSTAT		Gets status information of a file or directory.	●
—		File List Start	—	FLSFIRST		Declares a file list operation for getting file status information.	●
—		File List Next	—	FLS		Gets status of the next file in a file list operation.	●
—		File List End	—	FLSFIN		Declares the end of a file list operation.	●
—		Change Directory	—	FCD		Changes the current directory.	●
—		Concatenate File	—	FCAT		Concatenates two files.	●
—		Change File Attribute	—	FATRW		Changes the attribute of a specified file or directory.	●

Classification	FUNC No.	Instruction	Processing Unit	Mnemonic	Symbol	Function	Applicable CPU
							F3SP66-4S F3SP67-6S F3SP71-4N F3SP76-7N
UDP/IP Socket Communications	—	UDP/IP Open	—	UDPOPEN		Opens a UDP/IP socket.	●
	—	UDP/IP Close	—	UDPCLOSE		Closes a UDP/IP socket.	●
	—	UDP/IP Send Request	8 bits	UDPSND		Sends data from a using UDP/IP socket.	●
	—	UDP/IP Receive Request	8 bits	UDPRCV		Receives data from a UDP/IP socket to device.	●
TCP/IP Socket Communications	—	TCP/IP Open	—	TCPOPEN		Opens a TCP/IP socket.	●
	—	TCP/IP Close	—	TCPCLOSE		Closes a TCP/IP socket.	●
	—	TCP/IP Connect Request	—	TCPCNCT		Issues a connection request to a TCP/IP server.	●
	—	TCP/IP Listen Request	—	TCPLISN		Waits for a connection request from a TCP/IP client.	●
	—	TCP/IP Send Request	8 bits	TCPSND		Sends data using TCP/IP socket.	●
	—	TCP/IP Receive Request	8 bits	TCPRCV		Receives data from a TCP/IP socket to device.	●
FTP Client	—	FTP Client Open	—	FTPOPEN		Runs FTP client.	●
	—	FTP Client Quit	—	FTPQUIT		Exits from FTP client.	●
	—	FTP Client Put File	—	FTPPUT		Transfers a file to FTP server.	●
	—	FTP Client Put Unique File	—	FTPPUTU		Transfers a file to FTP server to be stored with a unique filename determined automatically by the server.	●
	—	FTP Client Append File	—	FTPAPEND		Transfers a file to FTP server to be appended to a specified file.	●
	—	FTP Client Get File	—	FTPGET		Gets a file from FTP server.	●
	—	FTP Client Change Directory	—	FTPCD		Changes current directory on FTP server.	●
	—	FTP Client Change Local Directory	—	FTPLCD		Changes local current directory on FTP client.	●
	—	FTP Client Current Directory Info	—	FTPPWD		Gets information about current directory of FTP server.	●
	—	FTP Client Get File List	—	FTPLS		Gets directory/file information from FTP server.	●
	—	FTP Client Delete File	—	FTPDEL		Deletes one or more files on FTP server.	●
	—	FTP Client Rename File	—	FTPREN		Renames a file on FTP server.	●
	—	FTP Client Make Directory	—	FTPMKDIR		Creates a directory on FTP server.	●
	—	FTP Client Remove Directory	—	FTPDIR		Deletes a directory on FTP server.	●
—	FTP Client Representation Type	—	FTPTYPE		Selects ASCII or binary for FTP data transfer.	●	
FTP Server	—	FTP Server Run Request Service	—	FTPSRUN		Resumes FTP server request service.	●
	—	FTP Server Stop Request Service	—	FTPSSTOP		Stops FTP server request service.	●
Miscellaneous	—	Write CPU Properties	—	PWRITE		Writes CPU property values.	●
	—	Read CPU Properties	—	PREAD		Reads CPU property values.	●

■ 64-bit Arithmetic and Comparison Instructions

Classification	FUNC No.	Instruction	Processing Unit	Mnemonic	Symbol	Function	Applicable CPU	
							F3SP71-4N F3SP76-7N	
Comparison	10D	Compare Double	=	64 bits	CMP D		Compares 4-word data.	—
			<>	64 bits				—
			>	64 bits				—
			>=	64 bits				—
			<	64 bits				—
			<=	64 bits				—
	904E	Compare Float Double	=	64 bits	FCMP E		Compares double-precision floating point data.	—
			<>	64 bits				—
			>	64 bits				—
			>=	64 bits				—
			<	64 bits				—
			<=	64 bits				—
Arithmetic	20D	Add Double	64 bits	CAL D		Adds 4-word data.	—	
		Subtract Double	64 bits			Subtracts 4-word data.	—	
		Multiply Double	64 bits			Multiplies 4-word data.	—	
		Divide Double	64 bits			Divides 4-word data.	—	
	903E	Add Double Float	64 bits	FCAL E		Adds double-precision floating-point data.	—	
		Subtract Double Double	64 bits			Subtracts double-precision floating-point data.	—	
		Multiply Double Float	64 bits			Multiplies double-precision floating-point data.	—	
		Divide Double Float	64 bits			Divides double-precision floating-point data.	—	
	122D	Square Root Double	64 bits	SQR D		Computes square root of 4-word data.	—	
	915E	Square Root Double Float	64 bits	FSQR E		Computes square root of double-precision floating-point data.	—	
Data Transfer	40D	Move Double	64 bits	MOV D		Moves 4-word data.	—	
Data Processing	951D	Extend Sign Double	64 bits	SIGN D		Extends sign of long-word data to double-word data	—	
	920L	Long Integer to Double Float	32 bits	ITOE L		Converts 2-word integer to double-precision floating-point data.	—	
	921D	Double Long Integer to Double Float	64 bits	ITOE D		Converts 4-word integer to double-precision floating-point data.	—	
	922L	Double Float to Long Integer	32 bits	ETOI L		Converts double-precision floating-point data to 2-word integer	—	
	923D	Double Float to Double Long Integer	64 bits	ETOI D		Converts double-precision floating-point data to 4-word integer	—	
	925F	Float to Double Float	32 bits	FTOE		Converts floating-point data to double-precision floating-point data.	—	
	926E	Double Float to Float	64 bits	ETOF E		Converts double-precision floating-point data to floating-point data.	—	
Elapsed Timer	965	Start Elapsed Timer (TMS)	32 bits	TMS L		Start elapsed timer and stores the free-run timer value into a specified device	—	
	966	Elapsed Time (TME)	32 bits	TME L		Stores result of elapsed time since timer is started by TMS into a specified device	—	

REAL-TIME BASIC

■ YM-BASIC/FA Basic Specifications

Type	Interpreter type (with pre-run function)	
Structure Programming	Possible using subprograms (no restriction in number)	
I/O Module Support	Contact inputs, contact outputs, analog inputs, analog outputs, personal-computer link, monitor, serial communication, pulse inputs, positioning, and so on.	
Data Types	Integer	-32,768 to 32,767 (internally 2-byte long)
	Double-precision integer	-2,147,483,648 to 2,147,483,647 (internally 4 bytes)
	Single-precision real	Absolute values range from approx. 2.7×10^{-20} to 9.2×10^{18} . The number of significant digits is approx. 7 (internally 4 bytes)
	Double-precision real	Absolute values range from approx. 2.7×10^{-20} to 9.2×10^{18} . The number of significant digits is approx. 16 (internally 8 bytes)
	Character string	512 bytes max.
Array	1- or 2-dimensional arrays are available. The number of elements allowed in an array: 1-dimensional array: 32,767; 2-dimensional array: 32,767 × 32,767	
Operators	(), ^, +, -, NOT, *, /, =, <, >, >=, <=, <>, AND, OR, EXOR	
Commands	28 (MS-DOS commands: 13)	
Subcommands	10 (used within EDIT)	
Statements	General statements	35
	Subprogram statements	4
	Basic I/O statements	7
	Real-time statements	12
	I/O module support statements	18
	Sequence statements	4
	Exception processing and debugging statements	11
Built-in Functions	Arithmetic built-in functions	13
	Bit manipulation built-in functions	15
	Character string manipulation built-in functions	16
	Other built-in functions	20
	Libraries	2

■ Command List

Statement	Function
Commands	
FREE	Displays the size of the free program area excluding common area (for both FA-M3 and personal computer).
RENUM	Renumbers lines.
DEL	Deletes subprograms and high-speed libraries.
SAVE	Saves into a program file.
LOAD	Loads a program stored in auxiliary memory into the user area.
MERGE	Merges a program stored in an auxiliary memory into the program in the user area.
APPEND (A)	Appends a program stored in auxiliary memory to the current program block in the user area.
LINKLIB	Loads a high-speed library into a program in the user area.
LIST (L)	Lists the program in the user area on a specified output device (CRT or printer).
ERLIST	Lists error lines from program listing (CRT or printer).
BYE	Exits debugging mode.
CONT	Resumes the execution of an interrupted program.
RUN	Executes a program in the user area.
NEW	Initializes (erases) the program in the user area.
PROG	Specifies the target program block for command processing.
AUTO	Causes line numbers to be generated automatically.
STEP	Single-steps program line.
EDIT	Starts a line editor.
LCOPY	Copies lines.
SETMD RUN	Turns on and off the BYE & RUN mode.
SETMD RES	Turns on and off program residency.
TRACE	Disables tracing of the location where a branch occurred.
SCRATCH	Enables a pause of the program execution.
TRACEP	Disables a pause of the program execution.
SCRATCHP	Enables tracing of variables.
TRACEV	Disables tracing of variables.
SCRATCHV	Displays the size of the free program area except for common area (for both FA-M3 and personal computer).
Subcommands (used within EDIT)	
QUIT(Q)	Quits the editor.
FIND(F)	Searches for a character string.
CHG(C)	Substitutes a character string.
APPEND(A)	Concatenates a specified line.
DEL	Deletes a specified line.
RENUM	Renumbers lines.
LCOPY	Copies lines.
LIST(L)	Displays program listing.
EDIT	Displays specified lines.
ERLIST	Displays error statement and error details.
MS-DOS Commands	
CHDIR	Changes directory and displays the current directory.
CLS	Clears the display panel.
XCOPY	Copies specified files.
DATE	Sets and displays the date (in the personal computer).
DEL	Deletes specified files.
DIR	Displays directory information.
MDIR	Creates a directory.
PATH	Sets a command search path.
REN	Renames a file.
RMDIR	Deletes a directory.
TIME	Sets and displays the time (clock in the personal computer).
TYPE	Displays the contents of a specified file.
VOL	Displays a volume label.

△: Cannot be executed if the FA-M3 is not connected to a personal computer.
 !: An MS-DOS* command is executed as part of this command.
 *: MS-DOS is a registered trademark of Microsoft Corporation.

■ Statement List

Statement	Function
Commands	
REM	Notes on a program.
DEFINT	Declares an integer type.
DEFLNG	Declares a long integer.
DEFSNG	Declares a single-precision real number.
DEFDBL	Declares a double-precision real number.
OPTION BASE	Specifies the starting index (lower limit) of an array.
DIM	Specifies an array.
ALLOCATE	Specifies an array of variable size.
DEF FN	Specifies a user function.
LET	Assigns a number.
MOVE	Moves an array.
SWAP	Swaps data.
READ	Reads data.
DATA	Defines data.
RESTORE	Defines a data read pointer.
GOTO	Causes an unconditional branch.
GOSUB	Causes a branch to a subroutine.
RETURN	Returns from a subroutine.
ON GOTO	Causes a branch according to computation result.
ON GOSUB	Causes a branch to a subroutine according to computation result.
IF-THEN-ELSE-ENDIF	Executes statements depending on conditions.
WHILE-END WHILE	Executes statements while conditions are met.
FOR-NEXT	Loops through statements.
STOP	Stops a program.
PAUSE	Suspends a program temporarily.
END	Terminates a program.
RANDOMIZE	Generates random numbers.
NEWL	Outputs blank lines with program listing.
CALLLIB	Causes a branch to a library.
CALL	Causes a branch to a subprogram.
COM	Declares a common variable.
SUBCOM	Specifies the beginning of a common area.
RECOM	Specifies the location of a common variable.
INIT COM	Initializes a common area.
Subprogram Statements	
SUB	Declares the beginning of a subprogram.
SUBEXIT	Returns from a subprogram.
SUBEXIT RETRY	Returns from a subprogram and re-execute.
SUBEND	Declares the end of a subprogram.
Basic I/O Statements	
PRINT (PR)	Prints.
PRINT USING (PU)	Prints with formatting.
IMAGE	Defines a format.
PRINT NOFORMAT	Prints without formatting.
DISP (DP)	Displays on a screen.
DISP USING (DU)	Displays formatted data on a screen.
Real-time Statements	
WAIT	Waiting for program execution.
ON TIME	Causes a branch at a specified time.
OFF TIME	Cancel a timed branch.
ON TIMER	Starts a timer.
OFF TIMER	Stops a timer.
DISABLE	Disables interrupts.
ENABLE	Enables interrupts.

□: Available in debugging mode

■ Statement List

Statement	Function
I/O Module Support Statements	
ASSIGN	Defines I/O module configuration.
ENTER	Inputs from an I/O equipment.
OUTPUT	Outputs to an I/O equipment.
TRANSFER	Starts buffered I/O.
ON EOT	Enables branching at end of transfer.
OFF EOT	Disables branching at end of transfer.
ENABLE INTR	Masks I/O interrupt sources.
ON INT	Enables branching on interrupt s
OFF INT	Disables branching on interrupts.
SET TIMEOUT	Sets I/O timeout interval.
ON TIMEOUT	Enables branching on I/O timeout.
OFF TIMEOUT	Disables branching on I/O timeout.
RESET	Resets I/O module.
STATUS	Reads status register.
CONTROL	Writes control register.
HALT	Cancels transfer.
SET STATUS	Sets I/O status information variable.
RESET STATUS	Resets I/O status information variable.
Sequence Statements	
COM #S-	Declares a common variable of shared registers.
ON SEQEVT	Declares interrupts from sequences.
OFF SEQEVT	Undeclares interrupts from sequences.
SEQACTV	Starts or stops a sequence program.
Exception Processing and Debugging Statements	
DEFAULT ON	Declares implicit processing to be executed on a computation error.
DEFAULT OFF	Undeclares implicit processing to be executed on a computation error.
ON ERROR	Declares branching on BASIC errors.
OFF ERROR	Undeclares branching on BASIC errors.
RETURN RETRY	Returns from a subroutine and re-executes.
TRACE	Enables tracing of the location where a branch occurs.
SCRATCH	Disables tracing of the location where a branch occurs.
TRACEP	Enables pause processing.
SCRATCHP	Disables pause processing.
TRACEV	Enables variable tracing.
SCRATCHV	Disables variable tracing.

-
-
-
-
-
-

Available in debugging mode

■ Built-in Function List

Built-in Function	Function
Arithmetic Functions	
SIN(x)	Gives the sine of x.
COS(x)	Gives the cosine of x.
TAN(x)	Gives the tangent of x.
ATN(x)	Gives the arc tangent of x.
EXP(x)	Gives value of the exponent for the natural number of x.
LOG(x)	Gives the natural logarithm of x.
SQR(x)	Gives the square root of x.
ABS(x)	Gives the absolute value of x.
SGN(x)	Gives the sign of x.
INT(x)	Gives the maximum integer not exceeding x.
RND(x)	Gives a random number in the range 0 < RND(x) < x.
DIV(A, B)	Gives the quotient of A divided by B.
MOD(A, B)	Gives the remainder of A divided by B.
Bit Manipulation Functions	
BINAND(m, n)	Gives bit-by-bit AND of m and n.
LBINAND(m, n)	Gives bit-by-bit AND of long integers m and n.
BINOR(m, n)	Gives bit-by-bit OR of m and n.
LBINOR(m, n)	Gives bit-by-bit OR of long integers m and n.
BINXOR(m, n)	Gives bit-by-bit XOR of m and n.
LBINXOR(m, n)	Gives bit-by-bit XOR of long integers m and n.
BINNOT(m)	Gives one's complement of n.
LBINNOT(m)	Gives one's complement of long integer n.
SHIFT(m, n)	Shifts m by n bits.
LSHIFT(m, n)	Shifts long integer m by n bits.
ROTATE(m, n)	Rotates (shifts) m by n bits.
LROTATE(m, n)	Rotates (shifts) long integer m by n bits.
LASTBIT	Gives the value of LASTBIT.
BIT(m, n)	Gives the value of the nth bit of m.
LBIT(m, n)	Gives the value of the nth bit value of long integer m.

Built-in Function	Function
Character String Manipulation Functions	
MID \$(c, m)	Gives a substring of string c, starting from the m-th to the last character, counted from left to right.
MID \$(c, m, n)	Gives n characters from string c starting at the m-th character, counted from left to right.
LEFT \$(c, m)	Gives m characters from string c starting from its left end.
RIGHT \$(c, m)	Gives m characters from string c starting from its right end.
CHR \$(n)	Generates a character equivalent to code value n.
STR \$(x)	Converts numeric value x to a character string.
VAL (c)	Converts a character string c to a numeric value.
ASC (c)	Gives the code of the first character in a character string c.
LEN (c)	Gives the number of characters in a character string c.
HLEN (c)	Gives the number of characters in a character string c in half size characters.
BLEN (c)	Gives the number of bytes in a character string c.
INSTR (c, m)	Searches a characters string c for substring m and gives the position of the first occurrence of m.
HMID \$(c, m, n)	Gives half-size MIDS.
LLEFT \$(c, n)	Gives half-size LEFTS.
HRIGHT \$(c, m)	Gives half-size RIGHTS.
HINSTR (c, m)	Gives half-size INSTR.
Other Functions	
PI	Gives the value of pi.
ERRL	Gives the line number of the last error.
ERRC	Gives the error code of the last error.
ERRCE	Gives the detailed error code of an I/O access error.
TIMEMS	Gives the time in milliseconds elapsed since 0.00.
RNPAR	Gives the parameters specified when the program is executed.
SPC (x)	Gives x spaces.
IOSIZE	Gives the number of bytes transferred during the last I/O operation.
HEX \$(x)	Gives the hexadecimal representation of x.
LHEX \$(x)	Gives the hexadecimal representation of x within long integer value range.
BCD (x)	Gives the BCD representation of x.
LBCD (x)	Gives the BCD representation of x within the long integer value range.
TIME \$	Gets the time.
DATE \$	Gets the date.
NAM (c)	Gets the value of simple variable expressed as c.
ARNAM (c, m)	Gets the value of element m of array c.
FREE	Gives the size of the unused program area.

■ Library List

Library	Function
INICOMM3	Initializes (clears) the shared register area of local CPU.
IFPCNV	Converts between the IEEE floating-point representation and YM-BASIC/FA internal representation.

Module Specifications

I/O Modules

Input Modules

Model	Input Type	Number of Points	Isolation Method	Rated Input Voltage	Rated Input Current	Operating Voltage/Current		Input Response Time		External Connection	Number of Points/Common																																						
						ON	OFF	OFF→ON	ON→OFF																																								
F3XH04-3N	DC voltage	4	Photocoupler isolation	24V DC	11.2 mA/point	16.0 V DC min. 7.2 mA min.	6.0 V DC max. 2.5 mA max.	50 μs max.	50 μs max.	10-point terminal block M3.5 screw	All points independent																																						
F3XA08-1N	AC voltage	8		100-120V AC 50/60Hz	5.4-6.5 mA/point 100-120 V AC, 60 Hz	80 V AC min. 5 mA min.	40 V AC max. 1 mA max.	15 ms max or 30 ms., selectable	25 ms max. or 40 ms, selectable	10-point terminal block M3.5 screw	8 points/common																																						
F3XA08-2N				200-240V AC 50/60Hz	5.1-6.1 mA/point 200-240 V AC, 60 Hz	160 V AC min. 4 mA min.	70 V AC max. 1 mA max.																																										
F3XA16-1N		16		100-120V AC 50/60Hz	5.4-6.5 mA/point 100-120 V AC, 60 Hz	80 V AC min. 5 mA min.	40 V AC max. 1 mA max.	Input sampling period can be specified within 0-16 ms in 5 levels ^{*1}	Input sampling period can be specified within 0-16 ms in 5 levels ^{*1}	18-point terminal block M3.5 screw	8 points/common																																						
F3XD08-6F	DC voltage (sink/ source)	8		12-24V DC	4.1 mA/point (12 V DC) 8.5 mA/point (24 V DC)	8.0 V DC min. 2.6 mA min.	3.4 V DC max. 1.0 mA max.			Input sampling period can be specified within 0-16 ms in 5 levels ^{*1}		Input sampling period can be specified within 0-16 ms in 5 levels ^{*1}	10-point terminal block M3.5 screw																																				
F3XD16-3F				16	24V DC	4.1 mA/point 24 V DC	16.0 V DC min. 3.2 mA min.						5.8 V DC max. 0.9 mA max.	2.0 ms max. or 17 ms, selectable	3.5 ms max. or 18.5 ms, selectable	18-point terminal block M3.5 screw																																	
F3XD16-4F		16			12V DC	4.1 mA/point 12 V DC	8.0 V DC min. 2.6 mA min.						3.4 V DC max. 1.0 mA max.			1.0 ms max.	1.0 ms max.	One 40-pin connector																															
F3XD32-3F				32	24V DC	4.1 mA/point 24 V DC	16.0 V DC min. 3.2 mA min.						5.8 V DC max. 0.9 mA max.					16 ms max	16 ms max.	One 40-pin connector																													
F3XD32-4F		32			12V DC	4.1 mA/point 12 V DC	8.0 V DC min. 2.6 mA min.						3.4 V DC max. 1.0 mA max.							Input sampling period can be specified within 0-16 ms in 5 levels ^{*1}	Input sampling period can be specified within 0-16 ms in 5 levels ^{*1}	Two 40-pin connectors																											
F3XD32-5F				32	5V DC	4.0 mA/point 5 V DC	3.5 V DC min. 2.0 mA min.						1.0 V DC max. 0.2 mA max.									16 ms max	16 ms max.	One 40-pin connector																									
F3XD64-3F		64			24V DC	4.1 mA/point 24 V DC	16.0 V DC min. 3.2 mA min.						5.8 V DC max. 0.9 mA max.											16 ms max	16 ms max.	Two 40-pin connectors																							
F3XD64-4F				64	12V DC	4.1 mA/point 12 V DC	8.0 V DC min. 2.6 mA min.						3.4 V DC max. 1.0 mA max.													16 ms max	16 ms max.	Two 40-pin connectors																					
F3XD08-6N		DC voltage (sink/ source)			8	12-24V DC	4.1 mA/point (12 V DC) 8.5 mA/point (24 V DC)						8.0 V DC min. 2.6 mA min.															3.4 V DC max. 1.0 mA max.	16 ms max	16 ms max.	10-point terminal block M3.5 screw																		
F3XD16-3N				16		24V DC	4.1 mA/point 24 V DC						16.0 V DC min. 3.2 mA min.															5.8 V DC max. 0.9 mA max.			16 ms max	16 ms max.	18-point terminal block M3.5 screw																
F3XD16-4N					16	12V DC	4.1 mA/point 12 V DC						8.0 V DC min. 2.6 mA min.															3.4 V DC max. 1.0 mA max.					16 ms max	16 ms max.	18-point terminal block M3.5 screw														
F3XD32-3N				32		24V DC	4.1 mA/point 24 V DC						16.0 V DC min. 3.2 mA min.															5.8 V DC max. 0.9 mA max.							16 ms max	16 ms max.	One 40-pin connector												
F3XD32-4N					32	12V DC	4.1 mA/point 12 V DC						8.0 V DC min. 2.6 mA min.															3.4 V DC max. 1.0 mA max.									16 ms max	16 ms max.	One 40-pin connector										
F3XD32-5N				32		5V DC	4.1 mA/point 5 V DC						3.5 V DC min. 2.0 mA min.															1.0 V DC max. 0.2 mA max.											16 ms max	16 ms max.	One 40-pin connector								
F3XD64-3N					64	24V DC	4.1 mA/point 24 V DC						16.0 V DC min. 3.2 mA min.															5.8 V DC max. 0.9 mA max.													16 ms max	16 ms max.	Two 40-pin connectors						
F3XD64-4N				64		12V DC	4.1 mA/point 12 V DC						8.0 V DC min. 2.6 mA min.															3.4 V DC max. 1.0 mA max.															16 ms max	16 ms max.	Two 40-pin connectors				
F3XD64-6M					DC voltage (matrix scan)		12-24V DC						3.9 mA/point (12 V DC) 8.2 mA/point (28 V DC)															8.0 V DC min. 2.6 mA min.																	3.4 V DC max. 1.0 mA max.	16 ms max	16 ms max.	One 40-pin connector	8 × 8 matrix
F3XD16-3H				DC voltage (+common)	16		24V DC						4.7 mA/point 24 V DC															16.0 V DC min. 3.2 mA min.																	5.8 V DC max. 0.9 mA max.	Input sampling period can be specified within 0-16 ms in 5 levels ^{*1} .	Input sampling period can be specified within 0-16 ms in 5 levels ^{*1} .	18-point terminal block M3.5 screw	8 points/common

*1: Indicated values apply to F3SP28, F3SP38, F3SP53, F3SP58, F3SP59, F3SP66, F3SP67, F3SP71 and F3SP76. When other CPU modules are used, the specifications are the same as F3XD□□-□□N.

The actual response time can be obtained by adding the following values:

For F3XD□□-□□F: 100 μs (OFF → ON)
300 μs (ON → OFF)

For F3XD16-3H: 10 μs

*2: When using input interrupts with F3XD□□-□□F, set the input sampling period to 62.5 μs or longer.

Model	Input Type	Number of Points	Isolation Method	Contact Rating	ON Resistance	OFF Resistance	Input Response Time		External Connection	Number of Points/Common
							OFF→ON	ON→OFF		
F3XC08-0N	Non-voltage connection	8	Transformer isolation	5 V DC min. 20 mA min.	200 Ωmax.	100 K Ωmin.	2.0 ms max. or 17 ms, selectable	2.0 ms max. or 17 ms, selectable	10-point terminal block M3.5 screw	18 points/common
F3XC08-0C							Input sampling period is selectable from 5 levels between 0 and 16 ms. (Response time is sampling period + 1 ms max.)	Input sampling period is selectable from 5 levels between 0 and 16 ms. (Response time is sampling period + 1 ms max.)	18-point terminal block M3.5 screw	8 points/independent common

● Output Modules

Model	Output Type	Number of Points	Isolation Method	Rated Load Voltage	Maximum Load Current	Output Response Time		Surge Protector	External Connection	External Power Supply	Number of Points/ Common	HOLD/RESET Output When Program Stops ³			
						OFF→ON	ON→OFF								
F3YD04-7N	Transistor contact	4	Photocoupler isolation	24V DC	2 A/point	5 ms max.	3 ms max.	Zener diode	10-point terminal block M3.5 screw	None	All points independent	When a sequence CPU is used: Initial value: RESET Configurable on module basis ² . When a BASIC CPU is used: No setup function is enabled; always HOLD.			
F3YA08-2N	TRIAC contact	8		100-240V AC	1 A/point (0-40°C) 0.7 A/point (40-55°C) 3 A/common	1 ms max.	1/2 cycle +1 ms max.	CR absorber varistor			8 points/ common				
F3YC08-0C	Relay contact		Mechanical isolation	24V DC 100-240V AC	2 A/point	10 ms max.	10 ms max.	None	18-point terminal block M3.5 screw	All points independent					
F3YC08-0N	Relay contact	2 A/point 8 A/common			8 points/ common										
F3YC16-0N	Relay contact	16	Photocoupler isolation	12-24V DC	1 A/point 4 A/common	1 ms max.	1 ms max.	Active clamp	10-point terminal block M3.5 screw	12-24 V DC 10 mA	8 points/ common				
F3YD08-6A	Transistor contact (sink type)	8									2 A/point 8 A/common		18-point terminal block M3.5 screw	12-24V DC 20mA	8 points/ common
F3YD08-6B	Transistor contact (source type)										0.5 A/point 2 A/common				6 points/ common
F3YD08-7A	Transistor contact (sink type)	14									0.1 A/point 0.5 A/common		One 40-pin connector	12-24 V DC 30 mA	8 points/ common
F3YD14-5A	Transistor contact (sink type)														
F3YD14-5B	Transistor contact (source type)	None									12-24 V DC 60 mA				
F3YD32-1A	Transistor contact (sink type)												64	16 mA/point 128 mA/common	5 V DC
F3YD32-1B	Transistor contact (source type)	24V DC									0.1 A/point 0.4A/common				
F3YD32-1H ^{*1}	Transistor contact (sink type)												0.1 A	16 ms max.	16 ms max.
F3YD32-1P ^{*4}	Transistor contact (sink type)	12-24V DC									0.1 A/point 0.4 A/common	1 ms max.			
F3YD32-1R ^{*4}	Transistor contact (source type)												None	12-24 V DC 110 mA	
F3YD32-1T	Transistor contact (TTL output)	64									0.1 A/point 0.4 A/common	1 ms max.			1 ms max.
F3YD64-1A	Transistor contact (sink type)												24V DC	0.1 A/point 0.4A/common	
F3YD64-1F ^{*1}	Transistor contact (sink type)	12-24V DC	0.1 A	16 ms max.	16 ms max.	One 40-pin connector	12-24 V DC 40 mA								
F3YD64-1M	Transistor contact (matrix scan)							0.1 A/point 0.4 A/common	1 ms max.	1 ms max.	Active clamp	Two 40-pin connectors			
F3YD64-1P ^{*4}	Transistor contact (sink type)	None	12-24 V DC 110 mA												
F3YD64-1R ^{*4}	Transistor contact (source type)			64	0.1 A/point 0.4 A/common	1 ms max.	1 ms max.	None							

*1: Can be configured to HOLD or RESET output in the event of a fatal failure when F3SP28, F3SP38, F3SP53, F3SP58, F3SP59, F3SP66, F3SP67, F3SP71 or F3SP76 is used.

*2: Configurable on 16-terminal basis when F3SP28, F3SP38, F3SP53, F3SP58, F3SP59, F3SP66, F3SP67, F3SP71 or F3SP76 is used.

*3: For details on the operation in the event of a CPU error, see "Severity of Failures and LED Display."

*4: Provided with output short-circuit protector.

● I/O Modules

Model	Input Type	Number of Points	Isolation Method	Rated Input Voltage	Rated Input Current	Operating Voltage/Current		Input Response Time		External Connection	Number of Points /Common	HOLD/RESET Output When Program Stops ⁴
						ON	OFF	OFF → ON	OFF → ON			
F3WD64-3F ¹ F3WD64-3P ⁵	DC voltage	32	Photo-Coupler isolation	24 V DC	4.1 mA/point	16 V DC min. 3.2 mA min.	5.8 V DC max. 0.9 mA max.	Can be specified within 0-1 ms in 4 levels ² .	Can be specified within 0-1 ms in 4 levels ² .	One 40-pin connector	8 points/ common	—
	Output Type	Number of Points		Rated Load Voltage	Maximum Load Current	Output Response Time		Surge Protector	External Power Supply	External Connection	Number of Points /Common	When a sequence CPU is used: Initial value: RESET Configurable on module basis ³ . When a BASIC CPU is used: No setup function is enabled: always HOLD
	Transistor contact (sink type)	32		24 V DC	0.1 A/point 0.4 A/common	1 ms max.	1 ms max.	Zener diode	24 V DC 60 mA (or 55 mA for F3WD64-3P)	One 40-pin connector	8 points/ common	

Model	Input Type	Number of Points	Isolation Method	Rated Input Voltage	Rated Input Current	Operating Voltage/Current		Input Response Time		External Connection	Number of Points /Common	HOLD/RESET Output When Program Stops ⁴
						ON	OFF	OFF → ON	OFF → ON			
F3WD64-4F ¹ F3WD64-4P ⁵	DC voltage	32	Photo-coupler isolation	12 V DC	4.1 mA/point	8 V DC min. 2.6 mA min.	3.4 V DC max. 1 mA max.	Can be specified within 0-1 ms in 4 levels ² .	Can be specified within 0-1 ms in 4 levels ² .	One 40-pin connector	8 points/ common	—
	Output Type	Number of Points		Rated Load Voltage	Maximum Load Current	Output Response Time		Surge Protector	External Power Supply	External Connection	Number of Points /Common	When a sequence CPU is used: Initial value: RESET Configurable on module basis ³ . When a BASIC CPU is used: No setup function is enabled: always HOLD
	Transistor contact (sink type)	32		12 V DC	0.1 A/point 0.4 A/common	1 ms max.	1 ms max.	Zener diode	12 V DC 60 mA (or 55 mA for F3WD64-4P)	One 40-pin connector	8 points/ common	

Model	Input Type	Number of Points	Isolation Method	Rated Input Voltage	Rated Input Current	Operating Voltage/Current		Input Response Time		External Connection	Number of Points /Common	HOLD/RESET Output When Program Stops ⁴
						ON	OFF	OFF → ON	OFF → ON			
F3WD64-3N	DC voltage	32	Photo-coupler isolation	24 V DC	4.1 mA/point	16 V DC min. 3.2 mA min.	5.8 V DC max. 0.9 mA max.	1.0 ms max.	2.5 ms max.	One 40-pin connector	8 points/ common	—
	Output Type	Number of Points		Rated Load Voltage	Maximum Load Current	Output Response Time		Surge Protector	External Power Supply	External Connection	Number of Points /Common	When a sequence CPU is used: Initial value: RESET Configurable on module basis ³ . When a BASIC CPU is used: No setup function is enabled: always HOLD
	Transistor contact (sink type)	32		24 V DC	0.1 A/point 0.4 A/common	1 ms max.	1 ms max.	Zener diode	24 V DC 60 mA	One 40-pin connector	8 points/ common	

Model	Input Type	Number of Points	Isolation Method	Rated Input Voltage	Rated Input Current	Operating Voltage/Current		Input Response Time		External Connection	Number of Points /Common	HOLD/RESET Output When Program Stops ⁴
						ON	OFF	OFF → ON	ON → OFF			
F3WD64-4N	DC voltage	32	Photo-coupler isolation	12 V DC	4.1 mA/point	8 V DC min. 2.6 mA min.	3.4 V DC max. 1 mA max.	1.0 ms max.	2.5 ms max.	One 40-pin connector	8 points/ common	—
	Output Type	Number of Points		Rated Load Voltage	Maximum Load Current	Output Response Time		Surge Protector	External Power Supply	External Connection	Number of Points /Common	When a sequence CPU is used: Initial value: RESET Configurable on module basis ³ . When a BASIC CPU is used: No setup function is enabled: always HOLD
	Transistor contact (sink type)	32		12 V DC	0.1 A/point 0.4 A/common	1 ms max.	1 ms max.	Zener diode	12 V DC 60 mA	One 40-pin connector	8 points/ common	

*1: Can be configured to HOLD or RESET output in the event of a fatal failure when F3SP28, F3SP38, F3SP53, F3SP58, F3SP59, F3SP66, F3SP67, F3SP71 or F3SP76 is used.

*2: Indicated values apply to F3SP28, F3SP38, F3SP53, F3SP58, F3SP59, F3SP66, F3SP67, F3SP71 and F3SP76. When other CPU modules are used, the specifications are the same as F3XD□□□□.

The actual response time can be obtained by adding the following values:

100 μs (OFF → ON)

300 μs (ON → OFF)

*3: Configurable on 16-terminal basis when F3SP28, F3SP38, F3SP53, F3SP58, F3SP59, F3SP66, F3SP67, F3SP71 or F3SP76 is used.

*4: For details on the operation in the event of a CPU error, see "Severity of Failures and LED Display."

*5: Provided with short-circuit protector.

■ Special Modules

● Analog I/O Modules

Model	I/O Type	Number of Points	Isolation Method	Input	Output	Resolution (12-bit A/D)	Total Accuracy	Conversion Speed	External Connection	External Power Supply
F3AD04-0N	Analog input	4	Photocoupler isolation	0 to 5 V DC 1 to 5 V DC -10 V to 10 V DC	-20,000 to 20,000	0 to 5 V/1 to 5 V DC: 1.4 mV -10 V to 10 V DC: 5.7 mV (12-bit A/D)	23 ±2°C ±0.2% (full scale) 0 to 55°C: ±0.5% (full scale)	1 ms × (number of inputs)	10-point terminal block M3.5 screws	—
F3AD08-1N		8							18-point terminal block M3.5 screws	
F3AD04-0V		4							10-point terminal block M3.5 screws	
F3AD08-1V		8							18-point terminal block M3.5 screws	
F3AD08-4V									0 to 20 mA DC 4 to 20 mA DC	
F3DA02-0N	Analog output	2	Photocoupler isolation	-20,000 to 20,000	-10 to 10 V DC 4 to 20 mA DC	Voltage output mode: 5.7 mV Current output mode: 5.7 µA (12-bit ADC)	23 ±2°C: ±0.2% (full scale) 0 to 55°C: ±0.5% (full scale)	2 ms fixed	10-point terminal block M3.5 screws	24 V DC ±10% 150 mA
F3DA04-1N								4 ms fixed	24 V DC ±10% 180 mA	
F3DA04-6R		4	Digital isolator	-30,000 to 30,000	-10 to 10 V 0 to 10 V 0 to 5 V 1 to 5 V 4 to 20 mA 0 to 20 mA -20 to 20 mA	Voltage output: ≈0.5 mV (for -10 to 10 V or 0 to 10 V range); ≈0.2 mV (for 0 to 5 V or 1 to 5 V range). Current output: ≈0.5 µA (for 4 to 20 mA range); ≈1 µA (for 0 to 20 mA or -20 to 20 mA range). (16-bit A/D)	Voltage output: ± 0.1% of FS (23±2°C with 10 MΩload); ± 0.3% of FS (0 to 55°C with 10 MΩload) Current output: ± 0.2% of FS (23±2°C with 100 Ωload); ± 0.3% of FS (0 to 55°C with 100 Ωload)	2 µs + 2 µs × (number of inputs)	18-point terminal block M3.5 screws	Rated voltage: 24 V DC Allowable range: 19.2 to 30 V DC Current consumption: 200 mA (inrush current: 1A)
										F3DA08-5N
F3DA08-5R		8	Digital isolator	-30,000 to 30,000	-10 V to 10 V 0 V to 10 V 0 V to 5 V 1 V to 5 V	Voltage output: 0.5 mV (for -10 to 10 V or 0 to 10 V range); 0.2 mV (for 0 to 5 V or 1 to 5 V range). (16-bit A/D)	Voltage output: ± 0.1% of FS (23±2°C with 10 MΩload); ± 0.3% of FS (0 to 55°C with 10 MΩload)	2 µs + 2 µs × (number of inputs)	18-point terminal block M3.5 screws	Rated voltage: 24 V DC Allowable range: 19.2 to 30 V DC Current consumption: 200 mA (inrush current: 1A)

● Analog Input Modules (High resolution type)

Model	I/O Type	Number of Points	Isolation Method	Input	Output	Resolution (12-bit A/D)	Total Accuracy	Conversion Speed	External Connection	External Power Supply
F3AD04-0R	Analog input	4	Photocoupler isolation	0 to 5 V DC 1 to 5 V DC -10 V to 10 V DC	-20,000 to 20,000	0 to 5 V/1 to 5 V DC: 0.175 mV -10 V to 10 V DC: 0.72 mV	23 ±2°C: ±0.1% (full scale) 0 to 55°C: ±0.3% (full scale)	1 ms × (number of inputs)	10-point terminal block M3.5 screw	—
F3AD08-1R									18-point terminal block M3.5 screw	
F3AD08-4R		8				0 to 20mA DC 4 to 20mA DC	23 ±2°C: ±0.1% (full scale) 0 to 55°C: ±0.2% (full scale)	50µs/100µs/ 250µs/500µs/ 1ms/16.6ms/ 20ms/100ms × (number of inputs); selectable on module basis		
F3AD08-5R						0 to 5 V DC 1 to 5 V DC -10 to 10 V DC 0 to 10 V DC			-10 to 10 V DC/0 to 10 V DC : 0.4mV -10 to 10 V DC/0 to 10 V DC : 0.5mV 0 to 20mA DC /4 to 20mA DC : 1.6µA	
F3AD08-6R	0 to 5 V DC 1 to 5 V DC -10 to 10 V DC 0 to 10 V DC 0 to 20mA DC 4 to 20mA DC	0 to 5 V DC/1 to 5 V DC : 0.4mV -10 to 10 V DC/0 to 10 V DC : 0.5mV 0 to 20mA DC /4 to 20mA DC : 1.6µA								

● High-speed Data Acquisition Module (Analog input)

Model	I/O Type	Number of Points	Isolation Method	Input	Output	Resolution (12-bit A/D)	Total Accuracy	Input Buffer	Data Acquisition Interval	External Connection
F3HA08-0N	Analog input	8	Photocoupler isolation	0 to 5V DC -10 to 10V DC	-20,000 to 20,000	0 to 5V DC: 1.4mV -10 to 10V DC: 5.7mV	23 ±2°C: ±0.2% (full scale) 0 to 55°C: ±0.5% (full scale)	24,576 words	50 to 30,000 µs	18-point terminal block M3.5 screw

● High-speed Counter Modules

Model	Input Type	Number of Points	Isolation Method	Input Signal				Input Frequency	Count-up Output	Output Condition	Output Contact Rating	External Connection
				Signal	Rated Input Voltage	Operating Voltage/Current						
						ON	OFF					
F3XP01-0H	DC voltage	1	Photocoupler isolation	A,B, PST	5V DC	3.5 V min. 10 mA min.	1.5 V max. 2 mA max.	0 to 100 kpps	2 points for each input point	Counter value = Set value	Transistor output: 5 to 24 V DC	One 40-pin connector
					12V DC	8 V min. 10 mA min.	2.4 V max. 2 mA max.					
					24V DC	16 V min. 10 mA min.	4.8 V max. 2 mA max.					
				EN	5V DC	3.5 V min. 3.2 mA min.	1.5 V max. 0.9 mA max.					
					12V DC	8 V min. 3.2 mA min.	2.4 V max. 0.9 mA max.					
					24V DC	16 V min. 3.2 mA min.	4.8 V max. 0.9 mA max.					

F3XP02-0H	DC voltage	2	Photocoupler isolation	A,B, PST	5V DC	3.5 V min. 10 mA min	1.5 V max. 2 mA max.	0 to 100 kpps	2 points for each input point	Counter value = Set value	Transistor output: 5 to 24 V DC	Two 40-pin connectors
					12V DC	8 V min. 10 mA min.	2.4 V max. 2 mA max.					
					24V DC	16 V min. 10 mA min	4.8 V max. 2 mA max.					
				EN	5V DC	3.5 V min. 3.2 mA min	1.5 V max. 0.9 mA max					
					12V DC	8 V min. 3.2 mA min	2.4 V max 0.9 mA max					
					24V DC	16 V min. 3.2 mA min	4.8 V max. 0.9 mA max.					

● Pulse Input Modules

Model	Input Type	Number of Points	Isolation Method	Rated Input Voltage	Operating Voltage/Current		Input Frequency	Count-up Output	Output Condition	Output Contact Rating	External Connection
					ON	OFF					
F3XS04-3N	DC voltage	4	Photocoupler isolation	24 V DC	16 V DC min. 7.2 mA min.	6 V DC max. 2.5 mA min.	0 to 20 kHz	4 independent points	Count value = Set value 1 Count value ≥ Set value 1 Count value = Set value 2 Count value ≥ Set value 2 Count value = \$0 return	Open collector output: 12 to 24 V DC	18-point terminal block M3.5 screw
F3XS04-4N				12 V DC	8.0 V DC min. 6.3 mA min.	3.5 V DC max. 2.4 mA min.					

● Positioning Modules

Model	Type	Number of Axes	Control Mode	Positioning Command Range	Speed Command Range	Acceleration/Deceleration	Interpolation Function	Data Backup	External Connection	External Power Supply
F3NC11-0N	Advanced mode with pulse output	1	Position control, speed control	-8,388,608 to 8,388,608	0.1 to 249,750 pps	Automatic trapezoidal ACC/DCC	Multiaxial linear Interpolation, 2-axis arc interpolation as specified by CPU instructions	Carried out by CPU module	One 40-pin connector	5 V DC 200 mA
F3NC12-0N		2								
F3NC32-0N	With pulse output	2	Position control, speed control	-2,147,483,648 to 2,147,483,648	0.1 to 5Mpps (by servo motor) 0.1 to 1 Mpps (by pulse motor)	Automatic trapezoidal ACC/DCC (starting speed programmable) Automatic S-shaped ACC/DCC (starting speed fixed)	1-axis movement, 2-axis linear Interpolation, 2-axis arc Interpolation	Carried out by flash memory or CPU module	One 48-pin connector	24V DC 80mA
F3NC34-0N		4					1-axis movement, 2/3/4-axis linear Interpolation, 2-axis arc Interpolation, 3/4-axis helical interpolation		Two 48-pin connectors	24V DC 120mA
F3NC51-0N	With analog voltage output (absolute encoder compatible)	1	Position control, speed control	-134,217,728 to 134,217,727	0.1 to 2 Mpps	Automatic trapezoidal ACC/DCC, 2-segment, S-shaped (3-segment)	Multiaxial linear interpolation, 2-axis arc interpolation as specified by CPU instructions	Carried out by CPU module	One 40-pin connector	24 V DC 10 mA
F3NC52-0N		2							Two 40-pin connectors	
F3NC61-0N	For torque control	1	Position control, speed control, torque control	-134,217,728 to 134,217,727 ¹	0.1 to 2 Mpps	Automatic trapezoidal ACC/DCC, 2-segment, S-shaped (3-segment)	—	Carried out by CPU module	One 40-pin connector	24 V DC 10 mA
F3NC96-0N	With MECHATROLINK-II interface	15	Position control, speed control, torque control	-2,147,483,648 to 2,147,483,647 ¹	1 to 2,147,483,647 ¹	Automatic trapezoidal ACC/DCC ¹	Linear interpolation as specified by CPU instructions, axis movement as specified by MECHATROLINK-II commands	Carried out by CPU module	One MECHATROLINK-II communication port	—
F3NC97-0N	With MECHATROLINK-III interface	15	Position control, speed control, torque control	-2,147,483,648 to 2,147,483,647 ¹	1 to 2,147,483,647 ¹	Automatic trapezoidal ACC/DCC ¹	Linear interpolation as specified by CPU instructions, axis movement as specified by MECHATROLINK-III commands	Carried out by CPU module	Two MECHATROLINK-III communication ports	—
F3YP04-0N	With multi-channel pulse output	4	Position control	-134,217,728 to 134,217,727	0.1 to 250 kpps	Automatic trapezoidal ACC/DCC	—	Carried out by CPU module	One 48-pin connector	5 V DC 350 mA
F3YP08-0N		8							Two 48-pin connectors	5 V DC 700 mA
F3YP14-0N	With multi-channel pulse output	4	Position control	-2,147,483,648 to 2,147,483,647	0.1 to 3,998,000 pps (by servo motor)	Automatic trapezoidal ACC/DCC (starting speed programmable) Automatic S-shape ACC/DCC (starting speed fixed)	—	Carried out by flash memory or CPU module	One 48-pin connector	5 V DC 350 mA
F3YP18-0N		8			0.1 to 499,750 pps (by pulse motor)				Two 48-pin connectors	5 V DC 700 mA

¹: Depends on the connected external instruments and the supported MECHATROLINK commands.

● Communication Modules

Model	Type	Transmission Specification					Protocol	External Power Supply
		Access Control Mode	Transmission Speed	Transmission System	Maximum Segment Length	Maximum Number of Nodes		
F3LE01-5T	Ethernet	CSMA/CD System	10 Mbps	Baseband	10BASE5: 500 m (2.5 km max. with a repeater) 10BASE-T: 100 m	100 segments (10BASE5) 2/segment (10BASE-T)	TCP/IP UDP/IP ICMP ARP	12 V DC, 500 mA (when 10BASE5 is used)
F3LE01-0T	Ethernet	CSMA/CD system	10 Mbps	Baseband	100 m	—	TCP/IP UDP/IP ICMP ARP	—
F3LE11-0T	Ethernet	CSMA/CD system	10 Mbps /100 Mbps	Baseband	100 m	—	TCP/IP UDP/IP ICMP ARP	—
F3LE12-0T	Ethernet	CSMA/CD System	10Mbps /100 Mbps	Baseband	100m	—	TCP/IP UDP/IP ICMP ARP	—
F3LX02-1N	FL-net (OPCN-2) Ver2.00	CSMA/CD system	10Mbps	Baseband	10BASE5: 500 m (2.5 km max. with a repeater) 10BASE-T: 100 m	254 nodes	UDP/IP ICMP ARP	12V DC 500mA (when 10BASE5 is used)
F3NX01-0N	Ethernet (Autonomous Distribution)	CSMA/CD system	10 Mbps	Baseband	10BASE5: 500 m (2.5 km max. with a repeater) 10BASE-T: 100 m	100 segments (10BASE5) 2/segment (10BASE-T)	UDP/IP ICMP ARP	12 V DC, 500 mA (when 10BASE5 is used)
F3NX01-1N	Ethernet (Autonomous Distribution)	CSMA/CD system	10 Mbps /100 Mbps	Baseband	100 m	—	UDP/IP ICMP ARP	—

Model	Type	Number of Ports	Insulation	Communication Mode	Transmission Speed	Synchronization	Maximum Transmission Distance	External Connection	
F3LC11-1F	Personal computer link (RS-232-C)	1	No	Half-duplex	115K bps max.	Start-stop synchronization	15 m	Dsub 9-pin connector	
F3LC12-1F	Personal computer link (RS-232-C)	2	No		19200 bps max.				
F3LC11-1N	Personal computer link (RS-232-C)	1	No		115K bps max.		1200 m	6-point terminal block M3.5 screw	
F3LC11-2F	Personal computer link (RS-422-A/RS-485)	1	Yes		19200 bps max.				
F3LC11-2N	Personal computer link (RS-422-A/RS-485)	1	Yes		38400 bps max.		15 m	Dsub 9-pin connector	
F3LC21-1N	Multi link (RS-232-C)	1	No		38400 bps max.		1200 m	6-point terminal block M3.5 screw	
F3LC51-2N	UT link (RS-422-A/RS-485)	1	Yes						
F3LH01-1N	YHLS	1	Yes	Full-duplex, Half-duplex	12M bps max.	Bit synchronization	300 m	European-type terminal block	
F3LH02-1N	YHLS	2	Yes					European-type terminal block	
F3LH02-0N	YHLS	2	Yes					8-pin modular plug (RJ-45)	
F3LP02-0N	FA link H	1	Yes	Cyclic broadcasting	12M bps max.	Frame synchronization	1 km	4-point terminal block M3.5 screw	
F3LP12-0N	Fiber-optic FA link H	1	Yes		1.25M bps			10 km	Optical connector
F3LR01-0N	Fiber-optic FA-bus	1	Yes	Both half-duplex bit serial transmission and cyclic scan are used.	10M bps	Bit synchronization	200 m	Optical connector	
F3LR02-0N	Fiber-optic FA-bus type 2	2	Yes					1.4 km	Optical connector
F3LR02-1W	FA-bus type 2	2	Yes					80 m	European-type terminal block
F3RS22-0N	RS-232-C ¹	2	No	Full-duplex, Half-duplex	19200 bps max.	Start-stop synchronization	15 m	Two Dsub 9-pin connectors	
F3RS41-0N	RS-422-A/RS-485 ¹	1	Yes					1200 m	6-point terminal block M3.5 screw
F3RZ81-0N	Ladder communication ² (RS-232-C)	1	No				15 m		
F3RZ81-0F	Ladder communication ² (RS-232-C)	1	No				15 m	Dsub 9-pin connectors	
F3RZ82-0F	Ladder communication ² (RS-232-C)	2	No				15 m	Two Dsub 9-pin connectors	
F3RZ91-0N	Ladder communication ² (RS-422-A/RS-485)	1	Yes				19200 bps max.	1200 m	6-point terminal block M3.5 screw
F3RZ91-0F	Ladder communication ² (RS-422-A/RS-485)	1	Yes						

*1: Compatible with BASIC CPUs.
*2: Compatible with sequence CPUs.

Model	Type	Interface	Number of Ports	Transmission System	Connection Configuration	Number of Devices	Handshake System
F3GB01-0N	GP-IB	ANSI/IEEE standard 488 compliant 24-pin receptacle connector (IEEE-488)	1	8-bit parallel, half-duplex	Star, multidrop	15 units max.	3-wire handshaking

Model	Type	Number of I/O Points	Maximum Message Length	Transmission				Media	Connection Configuration	Number of Nodes	Network Power Source	
				Speed	Distance		Maximum Length					Total Length
					Maximum Trunk Line Cable Length	Branch Line Length						
F3LD01-0N	Device Net	Input: 8000 Output: 8000	Send: 84 bytes Receive: 88 bytes (service data)	125K bps	500 m	100 m	6 m	156 m	5 dedicated cables Signal: 2 lines Shielded: 1 line Power source: 2 lines	Multidrop, T-branch	64 (including master)	Voltage: 24 V DC Current consumption: 40 mA max. (supplied via connector)
				250K bps	250 m			78 m				
				500K bps	100 m			39 m				

Model	Type	Interface	Number of I/O Points	Transmission			Number of Stations	Network Power Supply
				Rate	Configuration	Distance		
F3LA01-0N	ASI	AS-interface V2.1 compliant	434 max. (248 inputs, 186 outputs) V2.1 248 max. (124 inputs, 124 outputs) V2.0	167Kbps	Multidrop	Total length: 100 m	One ASI master, 1 power supply, 62 slaves max. (for V2.1) or 31 slaves max. (for V2.0)	Voltage: 30 VDC Current consumption: 200 mA max. (supplied via connector)

Model	Type	Interface	Number of I/O Points	Transmission			Connection Configuration	Number of Nodes
				Rate	Distance	Medium		
F3LB01-0N	PROFIBUS-DP	PROFIBUS-DP DPM1 (class 1) compliant	8192 (4096 inputs, 4096 outputs)	9.6 kbps	1200 m	2 dedicated cables (with 2 signal lines)	Bus connection	125 (including master)
				19.2 kbps	1200 m			
				93.75 kbps	1200 m			
				187.5 kbps	1000 m			
				500 kbps	400 m			
				1500 kbps	200 m			
				3 Mbps	100 m			
				6 Mbps	100 m			
				12 Mbps	100 m			

● Temperature Control and Monitoring Modules/PID Control Module/Temperature Control and PID Module/Temperature Monitoring Module

Model	Number of Loops	Isolation Method	Input	Output	Sampling Interval	Control Mode	External Connection	External Power Supply	
F3CT04-0N	4	Photocoupler Isolation*	Thermocouple: K, J, T, E, R, B, S, N, W, L, U, Platinel 2 DC voltage: 0 to 10 mV, 0 to 100 mV	Time proportional output (open collector/voltage pulse)	0.5 s	PID or ON/OFF	18-point terminal block	24 V DC 200 mA	
F3CT04-1N				Time proportional output (open collector/voltage pulse)					
F3CR04-0N				Time proportional output (open collector/voltage pulse)					
F3CR04-1N				Time proportional output (open collector/voltage pulse)					
F3CV04-1N		Photocoupler* and transformer isolation	RTD: JPt 100, Pt 100	DC voltage: 0 to 1 V, -1 V to 1 V 0 to 5 V, 1 to 5 V 0 to 10 V	Continuous output (4 to 20 mA) Time proportional output (open collector/voltage pulse)	0.2 s	PID, ON/OFF, Heating/cooling	18-point terminal block M3.5 screw	24 V DC 50 mA
F3CU04-0□				Thermocouple: K, J, T, B, S, R, N, E, L, U, W, Platinel 2	Time-proportional PID output (open collector)				24 V DC 250 mA
F3CU04-1□				RTD: JPt 100, Pt 100	Continuous PID output (4 to 20 mA) Time-proportional PID output (open collector)				—
F3CX04-0N				DC voltage: 0 to 10 mV, 0 to 100 mV, 0 to 1 V, 0 to 5 V, 1 to 5 V, 0 to 10 V,	—				0.2 s

* : - Input and output lines are photocoupler-isolated from internal circuitry.
 - Input channels are photocoupler-isolated from each other.
 - Output channels are not isolated from each other (shared by a common line, which is floating).

● Memory card module

Model	Memory Media	CF File System	Number of CF that can be inserted	Temperature range	Current Consumption
F3EM01-0N	Compact Flash (Type 1)	FAT 16 (long file names supported)	1	0°C to 55°C (but without exceeding the maximum temperature rated for the CF less 15°C)	300 mA (excluding the CF)

● Terminal Block Unit

Model	Number of Points	Rated Voltage	Operating Voltage Range	Maximum Current	Cable	Terminal Block Screw	Mounting Screw
TA40-0N	40	5-24 V DC	4.5 to 26.4 V DC	0.5 A DC/point	0.08 to 0.26 mm ²	M2 (minus thread)	M2.6 (minus thread)
TA50-0N	40	5-24 V DC	4.5 to 26.4 V DC	0.5 A DC/point	2 mm ² max.	M3.5	M4 (2 points)
TA50-1N	40	5-24 V DC	4.5 to 26.4 V DC	0.5 A DC/point	2 mm ² max.	M3	M4 (2 points)
TA60-0N	40	5-24 V DC	4.5 to 26.4 V DC	0.5 A DC/point	2 mm ² max.	M2	M4 (2 points)

■ YHLS Slave Units (TAH Series)

● Input Units

Model	Input Type	Number of Points	Isolation Method	Rated Input Voltage	Rated Input Current	Operating Voltage/Current		Input Response Time		External Connection	Number of Points /Common	External Power Supply
						ON	OFF	OFF→ON	ON→OFF			
TAHXD16-3PEM	DC voltage (+ common)	16	Photo-coupler isolation	24 V DC	4.1 mA/point	16.0 VDC min.	5.8 V DC max	1.0 ms max.	1.0 ms max.	MIL, 26 pins	16 points/ common	20.4-26.4V DC 100 mA
TAHXD16-3NEM	DC voltage (- common)					3.2 mA min.	0.9 mA min.					

● Output Units

Model	Output Type	Number of Points	Isolation Method	Rated Load Voltage	Maximum Load Current	Output Response Time		HOLD/RESET Output on YHLS Communication Error or when Program Stops	External Connection	Number of Points /Common	External Power Supply
						OFF→ON	ON→OFF				
TAHYD16-3EAM	Transistor contact (sink type)	16	Photo-coupler isolation	24 V DC	0.1 A/point	1 ms max.	1 ms max.	Configurable globally by DIP switch HLD:HOLD R:RESET	MIL, 26 pins	16 points/ common	20.4-26.4V DC 100 mA
TAHYD16-3EBM	Transistor contact (source type)										

● I/O Units

Model	Input Type	Number of Points	Isolation Method	Rated Input Voltage	Rated Input Current	Operating Voltage/Current		Input Response Time		External Connection	Number of Points /Common	External Power Supply
						ON	OFF	OFF→ON	ON→OFF			
TAHWD32-3PAM	DC voltage (+ common)	16	Photo-coupler isolation	24 V DC	4.1 mA/point	16.0 VDC min. 3.2 mA min.	5.8 VDC max. 0.9 mA min.	1.0 ms max.	1.0 ms max.	MIL, 26 pins	16 points/ common	20.4-26.4 V DC 100 mA
	Output Type											
	Transistor contact (sink type)	16	Photo-coupler isolation	24 V DC	0.1 A/point	1 ms max.	1 ms max.	Configurable globally by DIP switch HLD:HOLD R:RESET	MIL, 26 pins	16 points/ common		

Model	Input Type	Number of Points	Isolation Method	Rated Input Voltage	Rated Input Current	Operating Voltage/Current		Input Response Time		External Connection	Number of Points /Common	External Power Supply
						ON	OFF	OFF→ON	ON→OFF			
TAHWD32-3NBM	DC voltage (- common)	16	Photo-coupler isolation	24 V DC	4.1 mA/point	16.0 VDC min. 3.2 mA min.	5.8 VDC max. 0.9 mA min.	1.0 ms max.	1.0 ms max.	MIL, 26 pins	16 points/ common	20.4-26.4 V DC 100 mA
	Output Type											
	Transistor contact (source type)	16	Photo-coupler isolation	24 V DC	0.1 A/point	1 ms max.	1 ms max.	Configurable globally by DIP switch HLD:HOLD R:RESET	MIL, 26 pins	16 points/ common		

■ YHLS Slave Units (TAC Series)

● Input Units

Model	Input Type	Number of Points	Isolation Method	Rated Input Voltage	Rated Input Current	Operating Voltage/Current		Input Response Time		External Connection	Number of Points /Common	External Power Supply
						ON	OFF	OFF→ON	ON→OFF			
TACXD08-3AE	DC voltage (sink type)	8	Not isolated	24 V DC	4.3 mA/point	16.0 VDC min. (between the input and 24V+ terminals)	5.8 V DC max. (between the input and 24V+ terminals)	1.0 ms max.	1.0 ms max.	e-CON, 4 pins	8 points/ common	20.4-26.4V DC 80mA
TACXD16-3AM		16								MIL, 20 pins	16 points/ common	20.4-26.4V DC 140mA

● Output Units

Model	Output Type	Number of Points	Isolation Method	Rated Load Voltage	Maximum Load Current	Output Response Time		HOLD/RESET Output on YHLS Communication Error or when Program Stops	External Connection	Number of Points /Common	External Power Supply
						OFF→ON	ON→OFF				
TACYD08-1AE	Transistor contact	8	Not isolated	24 V DC	0.1 A/point	0.05 ms max.	0.5 ms max.	Configurable by DIP switch bit3 (H or R) H:HOLD R:RESET	e-CON, 4 pins	8 points/ common	20.4-26.4V DC 30 mA
TACYD16-1AM		16							MIL, 20 pins	16 points/ common	20.4-26.4V DC 30 mA
TACYC04-0NB	Relay contact	4	Physical isolation	24 V DC 250 V AC	1 A/point	10 ms max.	5.0 ms max.		European terminal block, 7 pins	2 points/ common	20.4-26.4V DC 70 mA

● I/O Units

Model	Input Type	Number of Points	Isolation Method	Rated Input Voltage	Rated Input Current	Operating Voltage/Current		Input Response Time		External Connection	Number of Points /Common	External Power Supply
						ON	OFF	OFF→ON	ON→OFF			
TACWD08-3NE	DC voltage (sink type)	4	Not isolated	24 V DC	4.3 mA/point	16.0 VDC min. (between the input and 24V+ terminals)	5.8 VDC max. (between the input and 24V+ terminals)	1.0 ms max.	1.0 ms max.	e-CON, 4 pins	4 points/ common	20.4-26.4 V DC 60 mA
	Output Type	Number of Points										
	Transistor contact	4	Not isolated	24 V DC	0.1 A/point	0.05 ms max.	0.5 ms max.	Configurable by DIP switch bit3 (H or R) H:HOLD R:RESET	e-CON, 4 pins	4 points/ common		

Model	Input Type	Number of Points	Isolation Method	Rated Input Voltage	Rated Input Current	Operating Voltage/Current		Input Response Time		External Connection	Number of Points /Common	External Power Supply
						ON	OFF	OFF→ON	ON→OFF			
TACWD16-3NM	DC voltage (sink type)	8	Not isolated	24 V DC	4.3 mA/point	16.0 VDC min. (between the input and 24V+ terminals)	5.8 VDC max. (between the input and 24V+ terminals)	1.0 ms max.	1.0 ms max.	MIL, 20 pins	8 points/ common	20.4-26.4 V DC 90mA
	Output Type	Number of Points										
	Transistor contact	8	Not isolated	24 V DC	0.1 A/point	0.05 ms max.	0.5 ms max.	Configurable by DIP switch bit3 (H or R) H:HOLD R:RESET	MIL, 20 pins	8 points/ common		

■ Restrictions on Module Installation Position

- The CPU module installed in slot 1 serves as the main CPU module.
- The CPU modules installed in slots 2 to 4 serve as add-on CPU modules.
- I/O modules may be installed in slots 2 to 4. Neither add-on sequence CPU modules nor add-on BASIC CPU modules can be installed in any slots whose slot number is greater than that of the installed I/O modules.
- When two or more CPU modules are to be used, no I/O modules can be installed between CPU modules.

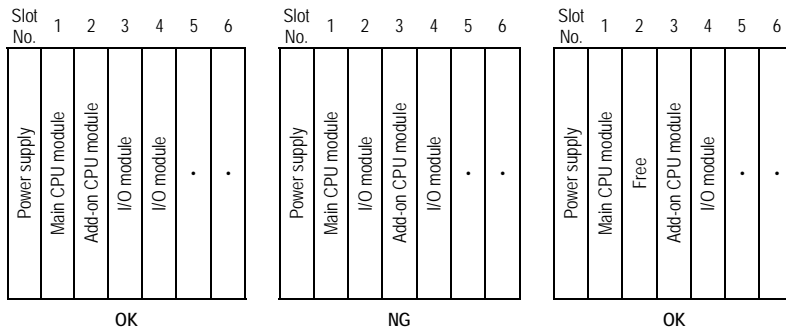

- For the F3SC21-1N FA-M3 Value, install the F3SP05-0P sequence CPU module in the leftmost slot of the 4-slot base module and the F3WD64-3N 64-point I/O module in slot No. 2.
- For the FA-M3 Value 2 of F3SC22-1F, F3SC22-2F or F3SC22-1A, install the F3SP08-□P Sequence CPU module in the leftmost slot of the 4 slot base module. For the F3SC22-1F or F3SC22-2F, install F3WD32-3F (with 32 I/O points) or F3WD64-3F (with 64 I/O points) in slot 2 respectively. For the F3SC22-1A, install the F3XD16-3F input module and the F3YD14-5A output module in slot 2 and slot 3 respectively.
- For the FA-M3 Value 2 of F3SC23-1F, F3SC23-2F, F3SC23-2P, F3SC23-6P or F3SC23-1A, install the F3SP08-□P Sequence CPU module in the leftmost slot of the 4 slot base module. For the F3SC23-1F or F3SC23-2F, install F3WD32-3F (with 32 I/O points) or F3WD64-3F (with 64 I/O points) in slot 2 respectively. For the F3SC23-1A, install the F3XD16-3F input module and the F3YD14-5A output module in slot 2 and slot 3 respectively.

■ Restrictions on the Number of CPU Modules

- A maximum of four CPU modules can be installed in slots 1 to 4 of the main unit.

Model	Number of Modules	Add-on CPU Module																
		F3SP21-0N	F3SP25-2N	F3SP35-5N	F3SP28-3□	F3SP38-6□	F3SP53-4□	F3SP58-6□	F3SP59-7S	F3SP6□-□S	F3SP7□-□N	F3BP20-0N	F3BP30-0N	F3FP36-3N				
Main CPU Module	F3SP21-0N	4	○	○	○	○	○	○	○	○	○	○	○	○	○	○	○	○
	F3SP25-2N	4	○	○	○	○	○	○	○	○	○	○	○	○	○	○	○	○
	F3SP35-5N	4	○	○	○	○	○	○	○	○	○	○	○	○	○	○	○	○
	F3SP28-3□	4	○	○	○	○	○	○	○	○	○	○	○	○	○	○	○	○
	F3SP38-6□	4	○	○	○	○	○	○	○	○	○	○	○	○	○	○	○	○
	F3SP53-4□	4	○	○	○	○	○	○	○	○	○	○	○	○	○	○	○	○
	F3SP58-6□	4	○	○	○	○	○	○	○	○	○	○	○	○	○	○	○	○
	F3SP59-7S	4	○	○	○	○	○	○	○	○	○	○	○	○	○	○	○	×
	F3SP6□-□S	4	○	○	○	○	○	○	○	○	○	○	○	○	○	○	○	○
	F3SP7□-□N	4	○*1	○*1	○*1	○	○	○	○	○	○	○	○	○	○	○	○	○
	F3BP20-0N	1	○	○	○	○	○	○	○	○	○	○	○	○	○	○	○	○
	F3BP30-0N	1	○	○	○	○	○	○	○	○	○	○	○	○	○	○	○	○
	F3FP36-3N	1	○	○	○	○	○	○	○	○	○	○	○	○	○	○	○	×

*1: Up to 2 modules can be installed for these combinations.

■ Restrictions on the Number of I/O Modules

- The table below summarizes the number of modules that a CPU module can gain direct access to and the number of modules that can be installed. The number of modules that can be installed here refers to I/O modules of the same type.
 - A circle denotes an I/O module that has no restriction as to the number of modules that can be installed.
 - An "x" denotes an I/O module to which the associated CPU module can gain no direct access.
 - A number indicates the number of I/O modules of the same type that can be installed.
- The restrictions to which I/O modules are subject to include those on the number of a particular type that can be installed and those on the total number of I/O modules of all types that can be installed in the entire system.

Modules to Which a CPU module Can Gain Direct Access and the Number of Modules that Can Be Installed (1 of 2)

Module Name	Model	Sequence CPU													Basic CPU		
		F3SP21-0N	F3SP25-2N	F3SP35-5N	F3SP28-3□	F3SP38-6□	F3SP53-4□	F3SP58-6□	F3SP59-7S	F3SP66-4S	F3SP67-4S	F3SP71-4N	F3SP76-7N	F3FP36-3N	F3BP20-0N	F3BP30-0N	
Memory card module	F3EM01-0N	2 ^{*1}	6 ^{*1}	6 ^{*1}	6 ^{*1}	6 ^{*1}	6 ^{*1}	6 ^{*1}	6 ^{*1}	6 ^{*1}	6 ^{*1}	6 ^{*1}	6 ^{*1}	x	x	x	
Input module	F3XA08-□N	○	○	○	○	○	○	○	○	○	○	○	○	○	○	○	
	F3XA16-□N	○	○	○	○	○	○	○	○	○	○	○	○	○	○	○	
	F3XH04-3N	16	16	16	16	16	16	16	16	16	16	16	16	16	16 ^{*2}	16 ^{*2}	
	F3XC08-0N	○	○	○	○	○	○	○	○	○	○	○	○	○	○	○	
	F3XC08-0C	○	○	○	○	○	○	○	○	○	○	○	○	○	○	○	
	F3XD08-6F	○	○	○	○	○	○	○	○	○	○	○	○	○	○	○	
	F3XD08-6N	○	○	○	○	○	○	○	○	○	○	○	○	○	○	○	
	F3XD16-□F	○	○	○	○	○	○	○	○	○	○	○	○	○	○	○	
	F3XD16-3H	○	○	○	○	○	○	○	○	○	○	○	○	○	○	○	
	F3XD32-□F	64	○	○	○	○	○	○	○	○	○	○	○	○	○	○	
	F3XD16-□N	○	○	○	○	○	○	○	○	○	○	○	○	○	○	○	
	F3XD32-□N	64	○	○	○	○	○	○	○	○	○	○	○	○	○	○	
	F3XD64-□□	32	64	○	64	○	64	○	64	○	64	○	64	○	64	○	
Output module	F3YA08-2N	○	○	○	○	○	○	○	○	○	○	○	○	○	○	○	
	F3YC08-0□	○	○	○	○	○	○	○	○	○	○	○	○	○	○	○	
	F3YC16-0N	○	○	○	○	○	○	○	○	○	○	○	○	○	○	○	
	F3YD04-7N	○	○	○	○	○	○	○	○	○	○	○	○	○	○	○	
	F3YD08-6□	○	○	○	○	○	○	○	○	○	○	○	○	○	○	○	
	F3YD08-7A	○	○	○	○	○	○	○	○	○	○	○	○	○	○	○	
	F3YD14-5□	○	○	○	○	○	○	○	○	○	○	○	○	○	○	○	
	F3YD32-1□	64	○	○	○	○	○	○	○	○	○	○	○	○	○	○	
	F3YD64-1□	32	64	○	64	○	64	○	64	○	64	○	64	○	64	○	
	F3YD64-□F	32	64	○	64	○	64	○	64	○	64	○	64	○	64	○	
I/O module	F3WD64-□N	32	64	○	64	○	64	○	64	○	64	○	64	○	64	○	
	F3WD64-□P	32	64	○	64	○	64	○	64	○	64	○	64	○	64	○	
	F3WD64-□□	32	64	○	64	○	64	○	64	○	64	○	64	○	64	○	
Analog input module	F3AD04-0□	36	36	36	36	36	36	36	36	36	36	36	36	36	36	36	
	F3AD08-0□□	36	36	36	36	36	36	36	36	36	36	36	36	36	36	36	
Analog output module	F3DA02-0N	36	36	36	36	36	36	36	36	36	36	36	36	36	36	36	
	F3DA04-1N	36	36	36	36	36	36	36	36	36	36	36	36	36	36	36	
	F3DA04-6R	36	36	36	36	36	36	36	36	36	36	36	36	36	36	36	
	F3DA08-5N	36	36	36	36	36	36	36	36	36	36	36	36	36	36	36	
	F3DA08-5R	36	36	36	36	36	36	36	36	36	36	36	36	36	36	36	
High-speed data acquisition module	F3HA08-0N	8	8	8	8	8	8	8	8	8	8	8	8	8	8	8	
Temperature control and monitoring module	F3CT04-□N	28	28	28	28	28	28	28	28	28	28	28	28	28	28	28	
	F3CR04-□N	28	28	28	28	28	28	28	28	28	28	28	28	28	28	28	
PID control module	F3CV04-1N	28	28	28	28	28	28	28	28	28	28	28	28	28	28	28	
Temperature control and PID module	F3CU04-□N	36	36	36	36	36	36	36	36	36	36	36	36	36	36	36	
Temperature monitoring module	F3CX04-0N	36	36	36	36	36	36	36	36	36	36	36	36	36	36	36	
Personal computer link module	F3LC11-1F	2 ^{*1}	6 ^{*1}	6 ^{*1}	6 ^{*1}	6 ^{*1}	6 ^{*1}	6 ^{*1}	6 ^{*1}	6 ^{*1}	6 ^{*1}	6 ^{*1}	6 ^{*1}	6 ^{*1}	6 ^{*1}	6 ^{*1}	
	F3LC11-1N																
	F3LC11-2F																
	F3LC11-2N																
	F3LC12-1F																
UT link module	F3LC51-2N	4	4	4	4	4	4	4	4	4	4	4	4	4	4		
DeviceNet interface module	F3LD01-0N	16	16	16	16	16	16	16	16	16	16	16	16	16	16	16	
Ethernet interface module	F3LE01-5T	2 ^{*1}	6 ^{*1}	6 ^{*1}	6 ^{*1}	6 ^{*1}	6 ^{*1}	6 ^{*1}	6 ^{*1}	6 ^{*1}	6 ^{*1}	6 ^{*1}	6 ^{*1}	6 ^{*1}	6 ^{*1}	6 ^{*1}	
	F3LE01-0T	2 ^{*1}	6 ^{*1}	6 ^{*1}	6 ^{*1}	6 ^{*1}	6 ^{*1}	6 ^{*1}	6 ^{*1}	6 ^{*1}	6 ^{*1}	6 ^{*1}	6 ^{*1}	6 ^{*1}	6 ^{*1}	6 ^{*1}	
	F3LE11-0T	2 ^{*1}	6 ^{*1}	6 ^{*1}	6 ^{*1}	6 ^{*1}	6 ^{*1}	6 ^{*1}	6 ^{*1}	6 ^{*1}	6 ^{*1}	6 ^{*1}	6 ^{*1}	6 ^{*1}	6 ^{*1}	6 ^{*1}	
	F3LE12-0T	2 ^{*1}	6 ^{*1}	6 ^{*1}	6 ^{*1}	6 ^{*1}	6 ^{*1}	6 ^{*1}	6 ^{*1}	6 ^{*1}	6 ^{*1}	6 ^{*1}	6 ^{*1}	6 ^{*1}	6 ^{*1}	6 ^{*1}	
YHLS master module	F3LH01-1N	28	28	28	28	28	28	28	28	28	28	28	28	28	28	28	
	F3LH02-1N	28	28	28	28	28	28	28	28	28	28	28	28	28	28	28	
	F3LH02-0N	15	15	15	15	15	15	15	15	15	15	15	15	15	15	15	
FL-net (OPC-2) interface module	F3LX02-1N	x	x	x	1 ^{*9/10}	2 ^{*9/10}	1 ^{*9/10}	2 ^{*9/10}	2 ^{*8}	1 ^{*8}	2 ^{*8}	1 ^{*8}	2 ^{*8}	x	x	x	
ASi master module	F3LA01-0N	32	36	36	36	36	36	36	36	36	36	36	36	36	36	36	
PROFIBUS-DP interface module	F3LB01-0N	16	16	16	16	16	16	16	16	16	16	16	16	16	16	16	
NX interface module	F3NX01-0N	2 ^{*1}	6 ^{*1}	6 ^{*1}	6 ^{*1}	6 ^{*1}	6 ^{*1}	6 ^{*1}	6 ^{*1}	6 ^{*1}	6 ^{*1}	6 ^{*1}	6 ^{*1}	6 ^{*1}	x	x	
	F3NX01-1N																
GP-IB communications module	F3GB01-0N ^{*7}	8	2 ^{*1}	8	6 ^{*1}	8	6 ^{*1}	8	6 ^{*1}	8	6 ^{*1}	8	6 ^{*1}	8	6 ^{*1}	8	6 ^{*1}
RS-232-C communications module	F3RS22-0N	x	x	x	x	x	x	x	x	x	x	x	x	x	36	36	
RS-422-A communications module	F3RS41-0N	x	x	x	x	x	x	x	x	x	x	x	x	x	36	36	
Ladder communications module	F3RZ81-0N	32	36	36	36	36	36	36	36	36	36	36	36	36	x	x	
	F3RZ81-0F	32	36	36	36	36	36	36	36	36	36	36	36	36	x	x	
	F3RZ82-0F	32	36	36	36	36	36	36	36	36	36	36	36	36	x	x	
	F3RZ91-0N	32	36	36	36	36	36	36	36	36	36	36	36	36	x	x	
	F3RZ91-0F	32	36	36	36	36	36	36	36	36	36	36	36	36	x	x	

Modules to Which a CPU module Can Gain Direct Access and the Number of Modules that Can Be Installed (2 of 2)

Module Name	Model	Sequence CPU													Basic CPU	
		F3SP21-0N	F3SP25-2N	F3SP35-5N	F3SP28-3□	F3SP38-6□	F3SP53-4□	F3SP58-6□	F3SP59-7S	F3SP66-4S	F3SP67-6S	F3SP71-4N	F3SP76-7N	F3FP36-3N	F3BP20-0N	F3BP30-0N
FA link H module	F3LP02-0N	2*3	8	8	8	8	8	8	8*3	8	8	×	×	8*3	×	×
Fiber-optic FA link H module	F3LP12-0N														×	×
Fiber-optic FA-bus module	F3LR01-0N	7*5	7*5	7*5	7*5	7*5	7*5	7*5	7*5	7*5	7*5	7*5	7*5	7*5	7*5	7*5
Fiber-optic FA-bus type 2 module	F3LR02-0N	*6	*6	*6	*6	*6	*6	*6	*6	*6	*6	*6	*6	*6	*6	*6
FA-bus type 2 module	F3LR02-1W															
High-speed counter module	F3XP01-0N	32	64	○	64	○	64	○	○	64	○	64	○	64	○	○
	F3XP02-0N	32	64	○	64	○	64	○	○	64	○	64	○	64	○	○
Pulse input module	F3XS04-□N	32	36	36	36	36	36	36	36	36	36	36	36	36	36	36
	F3YP04-0N	32	36	36	36	36	36	36	36	36	36	36	36	36	36	36
Positioning module (with multi-channel pulse output)	F3YP08-0N	32	36	36	36	36	36	36	36	36	36	36	36	36	36	36
	F3YP14-0N	32	36	36	36	36	36	36	36	36	36	36	36	36	36	36
	F3YP18-0N	32	36	36	36	36	36	36	36	36	36	36	36	36	36	36
Positioning module (advanced model with pulse output)	F3NC11-0N	32	36	36	36	36	36	36	36	36	36	36	36	36	36	36
	F3NC12-0N	32	36	36	36	36	36	36	36	36	36	36	36	36	36	36
Positioning module (with pulse output)	F3NC32-0N	16	16	16	16	16	16	16	16	16	16	16	16	16	16	16
	F3NC34-0N	16	16	16	16	16	16	16	16	16	16	16	16	16	16	16
Positioning module (with analog voltage output)	F3NC51-0N	32	36	36	36	36	36	36	36	36	36	36	36	36	36	36
	F3NC52-0N	32	36	36	36	36	36	36	36	36	36	36	36	36	36	36
Positioning module (for torque control)	F3NC61-0N	32	36	36	36	36	36	36	36	36	36	36	36	36	36	36
Positioning module (with MECHATROLINK-II interface)	F3NC96-0N	8	8	8	8	8	8	8	8	8	8	8	8	8	8	8
Positioning module (with MECHATROLINK-III interface)	F3NC97-0N	8	8	8	8	8	8	8	8	8	8	8	8	8	8	8

Install the module shaded by in the main unit.

- *1: The number indicates the total number of personal computer link modules, Ethernet interface modules, and GP-IB communications modules (slave mode). When two or more CPU modules of different maximum module limits are installed, the smallest maximum module limit value is taken as the total number of installable modules.
- *2: The pulse-capture function is not available.
- *3: The number indicates the total number of FA link H modules and fiber-optic FA link H modules. When two or more CPU modules of different maximum module limits are installed, the smallest maximum module limit value is taken as the total number of installable modules. The FA link H and fiber-optic FA link H modules are available for sequence CPU modules of Rev. 8 or later. For the revision number of a sequence CPU module, see the revision number label on the side panel.
- *4: Configured using Ladder Diagram Support Program M3.
- *5: The number indicates the total number of fiber-optic FA-bus modules, fiber-optic FA-bus Type 2 modules and FA-bus Type 2 modules that can be installed in the main unit. When two or more CPU modules of different maximum module limits are installed, the smallest maximum module limit value is taken as the total number of modules that can be installed. When sub-units are to be split using fiber-optic FA-bus Type 2 modules, the actual number of modules that can be installed may be greater than those listed in the above table depending on the split pattern used. For details, refer to "Fiber-optic FA-bus Module, Fiber-optic FA-bus Type 2 Module, FA-bus Type 2 Module User's Manual" (IM34M06H45-01E).
- *6: The fiber-optic FA-bus Type 2 modules and FA-bus Type 2 modules are available for sequence CPU modules of Rev. 8 or later. For the revision number of a sequence CPU module, see the revision number label on the side panel.
- *7: The maximum number of each module that can be installed depends on the operating mode. The left number and right number in each cell apply when the module is in master mode and slave mode respectively.
- *8: Up to a total of 6 personal computer link modules, Ethernet interface modules and GP-IB communication modules (when in slave mode) can be installed.
- *9: Up to 7 modules can be installed if used with FL-net interface module, provided link device capacities are not exceeded.
- *10: FL-net interface module can be used with sequence CPU modules rev. 5 or higher. There is no restriction when used with F3SP□□-□S modules.

■ Standard Accessories

Module name	Model	Accessory	Quantity
Base module	F3BU04-0N	Connector dust cover	2
	F3BU06-0N	Connector dust cover	2
	F3BU05-0D	Connector dust cover	2
	F3BU09-0N	Connector dust cover	4
	F3BU13-0N	Connector dust cover	4
	F3BU16-0N	Connector dust cover	4

■ Spare Parts

Item	Part No.	Applicable Module
Terminal (10-point terminal block)	A1474JT	F3XH04, F3XA08, F3XD08, F3YD04, F3YA08, F3YC08, F3YD08, F3AD04, F3DA02
Terminal (10-point terminal block) cover	A1472JT	
Terminal (18-point terminal block)	A1496JT	F3YC16, F3XA16, F3XD16, F3YD14, F3CR04, F3CV04, F3AD08, F3DA04, F3DA08, F3XS04, F3HA08
Terminal (18-point terminal block) cover	A1494JT	
Soldered-type connector (40-pin plug)	A1451JD	F3XD32, F3XD64, F3WD64, F3XP01, F3XP02, F3YD32, F3YD64, F3NC11, F3NC12, F3NC51, F3NC52, F3NC61
Connector (40-pin plug) cover (2 pieces)	A1452JD	
Soldered-type connector (48-pin plug)	A1612JD	F3YP04, F3YP08, F3YP14, F3YP18, F3NC32, F3NC34
Connector (48-pin plug) cover (2 pieces)	A1613JD	
Connector dust cover	T9031AS	F3BU04, F3BU06, F3BU05, F3BU09, F3BU13, F3BU16
	T9031AP	
Rail mount kit	T9031AQ	F3BU09, F3BU13

Current Consumption

Make sure that the total current consumption (at 5 V DC) in the installed modules does not exceed the 5 V power capacity of the power supply module used. Prepare an appropriate external power supply according to the specifications of the modules used.

■ Power Supply Modules

Model	Internal 5 V Source (mA)	Power Supplied to External Devices (mA)
F3PU10-0□	2000	No
F3PU16-0N	2000	No
F3PU20-0□	4300	No
F3PU26-0N	4300	No
F3PU30-0□	6000	No
F3PU36-0□	6000	No

■ Basic Modules

Module Name	Model	Maximum Current Consumption (mA) at 5 V DC	External Power Supply	
			Voltage (V DC)	Current (mA)
CPU module	F3SP21-0N	350	—	—
	F3SP25-2N	420	—	—
	F3SP35-5N	560	—	—
	F3SP28-3□	450	—	—
	F3SP38-6□	450	—	—
	F3SP53-4□	890	—	—
	F3SP58-6□	890	—	—
	F3SP59-7S	920	—	—
	F3SP66-4S	850	—	—
	F3SP67-6S	850	—	—
	F3SP71-4N	460	—	—
F3SP76-7N	460	—	—	
F3FP36-3N	560	—	—	
BASIC CPU module	F3BP20-0N	200	—	—
	F3BP30-0N	200	—	—
Base module	F3BU04-0N	50	—	—
	F3BU06-0N	50	—	—
	F3BU05-0D	50	—	—
	F3BU09-0N	50	—	—
	F3BU13-0N	50	—	—
	F3BU16-0N	50	—	—

■ FA-M3 Value and Value II

Module Name	Model	Power Supply			Sequence CPU	
		Internal 5 V Power Supply (mA)	Power Supplied to External Devices (mA)	Maximum Current Consumption (mA) at 5 V DC	External Power Supply	
					Voltage (V DC)	Current (mA)
FA-M3 Value Sequence CPU	F3SP05-0P	2000	No	350	—	—
FA-M3 Value 2 Sequence CPU	F3SP08-0P F3SP08-SP	2000	No	350	—	—

■ I/O Modules

Module Name	Model	Maximum Current Consumption (mA) at 5 V DC	External Power Supply	
			Voltage (V DC)	Current (mA)
High-speed input module	F3XH04-3N	30	—	—
AC input module	F3XA08-1N	40	—	—
	F3XA08-2N	40	—	—
	F3XA16-1N	65	—	—
DC input module	F3XD08-6F	40	—	—
	F3XD16-3F	65	—	—
	F3XD16-4F	65	—	—
	F3XD32-3H	65	—	—
	F3XD32-3F	75	—	—
	F3XD32-4F	75	—	—
	F3XD64-5F	75	—	—
	F3XD64-3F	100	—	—
	F3XD64-4F	100	—	—
	F3XD08-6N	40	—	—
	F3XD16-3N	65	—	—
	F3XD16-4N	65	—	—
	F3XD32-3N	75	—	—
	F3XD32-4N	75	—	—
	F3XD32-5N	75	—	—
	F3XD64-3N	100	—	—
	F3XD64-4N	100	—	—
	F3XD64-6M	110	12-24	70
	No-voltage contact input module	F3XC08-0N	75	—
F3XC08-0C		75	—	—
TRIAC output module	F3YA08-2N	130	—	—
Relay output module	F3YC08-0C	205	—	—
	F3YC08-0N	205	—	—
	F3YC16-0A	380	—	—
Transistor output module	F3YD04-7N	85	—	—
	F3YD08-6A	60	12-24	10
	F3YD08-6B	60	12-24	10
	F3YD08-7A	60	12-24	10
	F3YD14-5A	85	12-24	20
	F3YD14-5B	85	12-24	20
	F3YD32-1A	210	12-24	115
	F3YD32-1B	210	12-24	115
	F3YD32-1H	165	12-24	30
	F3YD32-1P	160	12-24	55
	F3YD32-1R	170	12-24	60
	F3YD32-1T	210	5	60
	F3YD64-1A	275	24	150
	F3YD64-1A	125	24	150
	F3YD64-1M	200	12-24	40
F3YD64-1P	275	12-24	95	
F3YD64-1R	275	12-24	110	
I/O module	F3WD64-3F	200	24	60
	F3WD64-4F	200	12	60
	F3WD64-3N	200	24	60
	F3WD64-4N	200	12	60
	F3WD64-3P	170	24	55
	F3WD64-4P	170	12	55

■ Special Modules

Module Name	Model	Maximum Current Consumption (mA) at 5 V DC	External Power Supply	
			Voltage (V DC)	Current (mA)
Analog input module	F3AD04-0N	210	—	—
	F3AD08-1N	210	—	—
	F3AD04-0V	210	—	—
	F3AD08-1V	210	—	—
	F3AD08-4V	210	—	—
	F3AD04-0R	210	—	—
	F3AD08-□R	210	—	—
Analog output module	F3DA02-0N	100	24	150
	F3DA04-1N	100	24	180
	F3DA04-6R	60	24	200
	F3DA08-5N	100	24	180
	F3DA08-5R	60	24	200
High-speed data acquisition module	F3HA08-0N	450	—	—
Temperature control and monitoring module	F3CT04-0N	250	24	200
	F3CT04-1N	250	24	200
	F3CR04-0N	250	24	200
	F3CR04-1N	250	24	200
PID control module	F3CV04-1N	250	24	200
Temperature control and PID module	F3CU04-0□	460	24	50
	F3CU04-1□	470	24	250
Temperature monitoring module	F3CX04-0N	440	—	—
Personal computer link module	F3LC11-1F	320	—	—
	F3LC11-1N	100	—	—
	F3LC11-2F	350	—	—
	F3LC11-2N	170	—	—
	F3LC12-1F	350	—	—
UT link module	F3LC51-2N	290	—	—
DeviceNet interface module	F3LD01-0N	200	—	—
Ethernet interface module	F3LE01-5T	330	12	500
	F3LE01-0T	500	—	—
	F3LE11-0T	500	—	—
	F3LE12-0T	500	—	—
FL-net (OPCN-2) interface module	F3LX02-1N	460	12	500
ASi Master module	F3LA01-0N	330	30	2000
PROFIBUS-DP Interface module	F3LB01-0N	610	—	—
YHLS master module	F3LH01-1N	360	—	—
	F3LH02-1N	480	—	—
	F3LH02-0N	440	—	—
NX interface module	F3NX01-0N	330	12	500
	F3NX01-1N	500	—	—
RS-232-C communications module	F3RS22-0N	110	—	—
RS-422A communications module	F3RS41-0N	210	—	—
Ladder communications module	F3RZ81-0N	100	—	—
	F3RZ81-0F	320	—	—
	F3RZ82-0F	350	—	—
	F3RZ91-0N	210	—	—
	F3RZ91-0F	350	—	—
GP-IB communications module	F3GB01-0N	250	—	—
FA link H module	F3LP02-0N	470	—	—
Fiber-optic FA link H module	F3LP12-0N	495	—	—
Fiber-optic FA-bus module	F3LR01-0N	220	—	—
Fiber-optic FA-bus type 2 module	F3LR02-0N	460	—	—
FA-bus type 2 module	F3LR02-1W	320	—	—
High-speed counter module	F3XP01-0H	100	—	—
	F3XP02-0H	150	—	—
Pulse input module	F3XS04-3N	230	—	—
	F3XS04-4N	230	—	—
Positioning module (advanced model with pulse output)	F3NC11-0N	180	5	200
	F3NC12-0N	180	5	200
Positioning module (with pulse output)	F3NC32-0N	450	24	80
	F3NC34-0N	540	24	120
Positioning module (with analog voltage output)	F3NC51-0N	390	24	10
	F3NC52-0N	400	24	10
Positioning module (for torque control)	F3NC61-0N	580	24	10
Positioning module (with MECHATROLINK-II Interface)	F3NC96-0N	570	—	—
Positioning module (with MECHATROLINK-III Interface)	F3NC97-0N	530	—	—
Positioning module (with multi-channel pulse output)	F3YP04-0N	300	5	200
	F3YP08-0N	350	5	400
	F3YP14-0N	320	5	350
	F3YP18-0N	380	5	700
Memory card module	F3EM01-0N	300	—	—

Severity of Failures and LED Display
(For F3SP21, F3SP25, F2SP35 and F2FP36 CPU modules)

Error Severity	LED Display	Description	Error Item	FAIL-signal Contact Output		Status of Output Module	
				Between FAIL 1 and COM	Between FAIL 2 and COM	Modules with 32 or less output points	Modules with 64 output points ²
Major	RDY (green) off	The core hardware is disabled.	- CPU error - Memory error	Shorted	Open	Initial value: RESET Configurable on module basis.	All settings are invalid; always HOLD
Moderate	ERR (red) lit	The user program cannot be started or run any further.	- Program error - I/O comparison error ¹ - I/O module error ¹ - Memory error - SPU error - Instruction processing error ¹ - Scan timeout ¹ - Startup error - Invalid instruction found - Too many I/O points - ROM pack error - Subroutine error ¹ - Interrupt error ¹ - Sub-unit communication error ¹	Shorted	Open	Initial value: RESET Configurable on module basis.	Initial value: RESET Configurable on module basis.
Minor	ALM (yellow) lit	The program can still run in spite of a failure.	- Momentary power failure - Inter-CPU communication error - Subunit line switchover	Open	Shorted	Operation continues.	Operation continues.

¹: Can be configured as minor failure or moderate failure.

²: Including F3WD64 and advanced modules that have output relays (Y□□□□□).

Severity of Failures and LED Display
(For F3BP20 and F3BP30 CPU modules)

Error Severity	LED Display	Description	Error Item	FAIL-signal Contact Output		Status of Output Module	
				Between FAIL 1 and COM	Between FAIL 2 and COM	Modules with 32 or less output points	Modules with 64 output points ²
Major	RDY (green) off	The core hardware is disabled.	- CPU error - Memory error	Shorted	Open	Initial value: HOLD Configurable on 8-terminal basis (using the CONTROL statement).	All settings are invalid; always HOLD
Moderate	ERR (red) lit	The user program cannot be started or run any further.	- Program error - I/O module error - BASIC error stop (No ON ERROR declaration)	Open	Shorted	All settings are invalid; always HOLD	All settings are invalid; always HOLD
Minor	ALM (yellow) lit ¹	The program can still run in spite of a failure.	- Power failure - I/O module error (during interrupt processing)	Open	Shorted	Operation continues.	Operation continues.

¹: The ALM LED (yellow) is also lit in the debugging mode.

²: Including F3WD64 and advanced modules that have output relays (Y□□□□□).

■ **Severity of Failures and LED Display**
(For F3SP28, F3SP38, F3SP5□, F3SP6□ and F3SP7□ CPU modules)

Error Severity	LED Display	Description	Error Item	FAIL-signal Contact Output		Status of Output Module	
				Between FAIL 1 and COM	Between FAIL 2 and COM	Output modules with 32 or fewer outputs, F3YD64-1F, F3YD64-1P, F3YD64-1R, F3WD64-□F and F3WD64-□P	F3YD64-1A, F3YD64-1M, F3WD64-□N, and Y□□□□□ ^{*2}
Major	RDY (green) off	The core hardware is disabled.	- CPU error - Memory error	Shorted	Open	Initial value: RESET Configurable on 16-point basis.	All settings are invalid; always HOLD
Moderate	ERR (red) lit	The user program cannot be started or run any further.	- Program error - I/O comparison error ^{*1} - I/O module error ^{*1} - Memory error - SPU error - Instruction processing error ^{*1} - Scan timeout ^{*1} - Startup error - Invalid instruction found - Too many I/O points - ROM pack error - Subroutine error ^{*1} - Interrupt error ^{*1} - Subunit communication error ^{*1} - Sensor control scan timeout ^{*1}	Shorted	Open	Initial value: RESET Configurable on 16-terminal basis.	Initial value: RESET Configurable on 16-terminal basis.
Minor	ALM (yellow) lit	The program can still run in spite of a failure.	- Momentary power failure - Inter-CPU communication error - Subunit line switchover	Open	Shorted	Operation continues.	Operation continues.

*1: Can be configured as minor failure or moderate failure.

*2: Output relays (Y□□□□□) of advanced modules.

External Dimensions

The figure below shows the external dimensions of the FA-M3 with a 16-slot base module, excluding the power supply module.

Unit: mm

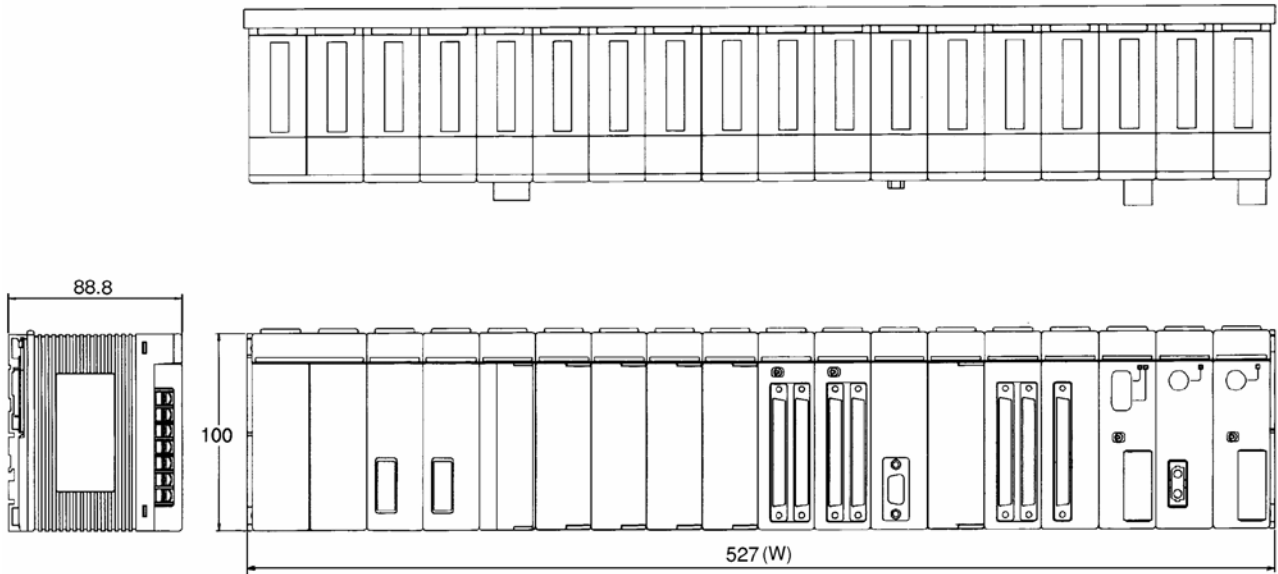

Base Module	Style	Number of Slots	Number of I/O Slots*	Width
F3BU04-0N	—	4	3	147 mm
F3BU06-0N	—	6	5	205 mm
F3BU05-0D	—	5	4	205 mm
F3BU09-0N	—	9	8	322 mm
F3BU13-0N	—	13	12	439 mm
F3BU16-0N	—	16	15	527 mm

- *: Number of I/O slots that can be installed in a single CPU module.
- Mounting screw for securing optional modules on the base module: M4 × 12 mm
 - Note 1: Mounting screws are not provided with the base module. Four mounting screws are required for F3BU04, F3BU06 and F3BU05 modules. Four or five are required for F3BU09 and F3BU13 modules. Six or seven are required for the F3BU16 module.
 - Note 2: Mounting screw specifications:
M4 binding head screw, 12-15 mm long (14-15 mm when a washer is used).
- These modules, except for the F3BU16 module, can be mounted on a DIN rail using the T9631AP rail-mount kit.

FA-M3 Approved / Compliant Standard:

For the UL-approved / CE Mark-compliant modules of FA-M3, see the General Specifications (GS 34M06C11-21E).

Trademarks

- MS-DOS is a registered trademark of Microsoft Corporation.
- Ethernet is a registered trademark of XEROX Corporation.
- Other product and company names appearing in this document are trademarks or registered trademarks of their respective holders.